

T321



ADL 系列电能表  
ADL Series Electricity Meter

安装使用说明书 T1.0  
Installation and Operation Instructions T1.0

安科瑞电气股份有限公司

Acrel Electric Co., Ltd.

## 申明

### Statement

版权所有，未经本公司之书面许可，此手册中任何段落、章节内容均不得摘抄、拷贝或以任何形式复制、传播，否则一切后果由违者自负。

All rights reserved. Without the written permission of the Company, any paragraph or section of this manual shall not be extracted, copied or reproduced or distributed in any form. Otherwise, all consequences shall be borne by the violator.

本公司保留一切法律权利。

The Company reserves all legal rights.

本公司保留对本手册所描述之产品规格进行修改的权利，恕不另行通知。订货前，请垂询当地代理商以获悉本产品的当前规格。

Our Company reserves the right to modify the product specifications described in this manual without further notice. Please consult your local agent for the current specifications of this product before placing an order.

## 安全信息

### safe Information

这份手册并未包含操作设备（模块、设备）的所有安全措施，因为特殊的操作条件、当地的法规要求或规定可能需要采取进一步的措施。然而，它包含了一些必须阅读的信息，这些信息关系到您的人身安全和避免物质损害。这些信息通过一个警告三角形来强调，并根据潜在危险的程度如下表示。

This manual does not contain all of the safety measures for operation of the equipment(module, device),because special operating conditions, and local code requirements or regulations may necessitate further measures. However,it does contain information which must be read for your personal safety and to avoid material damages. This information is highlighted by a warning triangle and is represented as follows, depending on the degree of potential danger.



“危险”表示一种危险的情况，如果不加以避免，将导致死亡或重伤。  
不遵循这些说明将导致死亡或重伤。

DANGER indicates a hazardous situation which, if not avoided, will result indeath or serious injury.  
Failure to follow these instructions will result in death or serious injury.



“警告”表示一种危险的情况，如果不加以避免，可能导致死亡或重伤。

WARNING indicates a hazardous situation which, if not avoided, could resultin death or serious injury.



“小心”表示一种危险的情况，如果不加以避免，可能导致轻度或中度伤害。

CAUTION indicates a hazardous situation which, if not avoided, could result inminor or moderate iniury.

# 目 录

## Contents

1. 概述.....	1
1.Overview.....	1
2. 型号说明.....	1
2.Description of Model.....	1
3 功能列表.....	2
3 List of Functions.....	2
4 技术参数.....	2
4 Technical Parameters.....	2
5 外形尺寸.....	5
5 Overall Dimensions.....	5
5.1 仪表尺寸.....	5
5.1 Instrument Dimensions.....	5
5.2 互感器尺寸.....	6
5.2 Transformer Dimensions.....	6
6 安全措施.....	6
6 safety measures.....	6
7 接线与安装.....	7
7 Connection and Installation.....	7
7.1 安装.....	7
7.1 Installation.....	7
7.2 电压电流接线示意图.....	8
7.2 Schematic Diagram of Voltage and Current Connection.....	8
7.3 功能性端子.....	9
7.3 Functional Terminal.....	9
8 主要功能特点.....	11
8 Main Functional Features.....	11
8.1 测量功能.....	11
8.1 Measurement Function.....	11
8.2 计量功能.....	11
8.2 Metering Function.....	11
9 操作与显示.....	11
9 Operation and Display.....	11
9.1 按键功能说明.....	11
9.1 Key Function Description.....	11
9.2 显示界面.....	12
9.2 Display Interface.....	12
10 通信说明.....	12
10 Communication Instructions.....	12
10.1 地址表.....	13
10.1 Address Table.....	13
11 常见故障分析.....	17

11 Common Fault Analysis.....	17
11.1 显示故障（电压电流功率显示异常） .....	17
11.1 Display Fault (Abnormal Voltage, Current, and Power Indications).....	17
11.2 通讯故障.....	17
11.2 Communication Fault.....	17
12 运输与贮存.....	17
12 Transportation and Storage.....	17
13. 保修与服务.....	18
13. Warranty and Service.....	18

# 1. 概述

## 1. Overview

ADL 系列导轨式多功能电能表，是主要针对于光伏并网系统、微逆系统、储能系统、交流耦合系统等新能源发电系统而设计的一款智能仪表，产品具有精度高、体积小、响应速度快、安装方便等优点。具有对电力参数进行采样计量和监测，逆变器或者能量管理系统（EMS）与之进行通讯，根据实时功率及累计电能实现防逆流、调节发电量、电池充放电等功能，可双向计量，实现户用分布式光伏能量管理。

ADL series DIN-rail mounted multifunctional electric energy meter is an intelligent instrument mainly designed for new energy power generation systems such as photovoltaic grid-connected system, micro inverter system, energy storage system, AC coupling system, etc. The product has the advantages of high precision, small volume, high respond speed and convenient installation. The product has the features of sampling, metering and monitoring power parameters, communicating with an inverter or an energy management system (EMS), realizing the functions of preventing reverse flow, regulating power generation, charging and discharging batteries according to real-time power and accumulated electric energy, and realizing bidirectional metering and household distributed photovoltaic energy management.

## 2. 型号说明

### 2. Description of Model

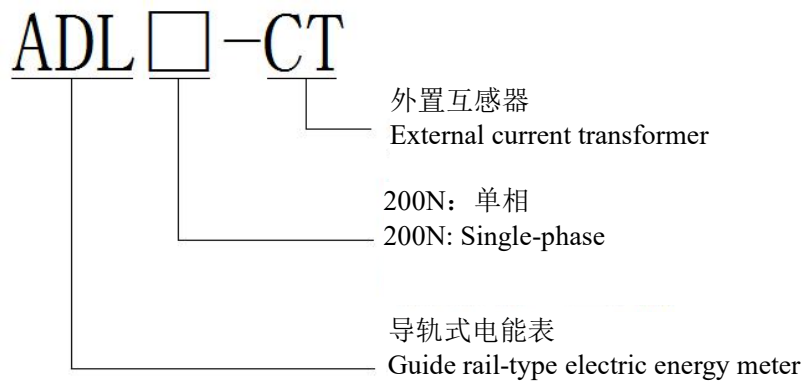

### 3 功能列表

### 3 List of Functions

表 1 功能说明列表

Table 1 List of Function Descriptions

功能 Function	功能说明 Descriptions	ADL200N-CT
电能计量 Electric energy metering	有功电能计量（正、反向） Active energy metering (forward and reverse)	■
	无功电能计量（正、反向） Reactive energy metering (forward and reverse)	■
电量测量 Electric quantity measurement	U, I	■
	P, Q, S, PF, F	■
LCD 显示 LCD display	段式 LCD 显示 Segmented LCD display	■
脉冲输出 Pulse output	有功脉冲输出 Active pulse output	■
通讯 Communication	RS485 接口，支持 Modbus RTU 规约 RS485: Modbus RTU	■

### 4 技术参数

### 4 Technical Parameters

表 2 技术参数说明

Table 2 Description of Technical Parameters

项目 Item		性能参数 Performance Parameters	
型号系列 Model Series		ADL200N-CT	
Measurement 测量	网络 Grid	单相 Single-phase	
	Voltage 电压	额定电压 Rated voltage	AC 230V
		输入范围 Input Range	±20%
		过负荷 Overload	1.2 倍额定值（连续） 1.2 times rating (continuous) 2 倍额定值持续 1 秒 2 times the rating for 1 second
		功耗 Power consumption	<2W, <10VA

		精度等级 Accuracy class	误差±0.5% Error ±0.5%
	Current 电流	输入电流 Input current	AC 0.5-10(80)A, AC 0.5-10(120)A
		过负荷 Overload	1.2 倍额定值 (连续) 1.2 times rating (continuous) 2 倍额定值持续 1 秒 2 times the rating for 1 second
		功耗 Power consumption	<1W, <1VA
		精度等级 Accuracy class	误差±0.5% Error ±0.5%
		功率 Power	有功、无功、视在功率, 误差±0.5% Active, reactive, apparent power, error ±0.5%
		电网频率 Grid frequency	50/60Hz, 误差±0.5% 50/60Hz, error ±0.5%
		响应速率 Response rate	≤100ms (电压、电流、功率) ≤100ms (voltage, current, power)
			≤1s (电能) ≤1s (electrical energy)
		测量类别 Measurement category	CAT III
		过电压等级 overvoltage level	OVC III
Metering 计量	电能 Electric energy	有功电能: B 级 Active energy : Class B 无功电能 (准确度等级 2 级) Reactive energy (Class 2 accuracy)	
consumption power 功耗	≤2W		
electromagnetic compatibility 电磁兼容	E2		
Security 安全性	工频耐压 Power frequency withstand voltage	通信与信号输入之间 AC3kV 1min Between communication and signal input, AC3kV 1min	
	绝缘电阻 Insulation resistance	输入、输出端对机壳>100MΩ Input and output terminals to casing >100MΩ	
Communication 通信	接口与通信规约 Interface and communication protocol	RS485 口、Modbus RTU 规约 RS485 interface and Modbus RTU protocol	
	通信地址范围 Communication address range	Modbus RTU:1~ 247;	



	波特率 Baud rate	支持 1200bps-38400bps Support 1200bps-38400bps
Environment 环境	工作温度 Operating temperature	-40°C~+70°C
	储存温度 Storage temperature	-40°C~+80°C
	相对湿度 Relative humidity	≤95% (无凝露) ≤95% (without condensation) 不适用潮湿环境 "Not suitable for damp environments"
	海拔高度 Altitude	≤2000m
参考标准 reference standard	<p>EN IEC 61010-1:2010 Safety requirements for electrical equipment for measurement, control, and laboratory use - Part 1: General requirements</p> <p>EN IEC 61010-2-030:2010 Safety requirements for electrical equipment for measurement, control, and laboratory use - Part 2-030: Particular requirements for equipment having testing or measuring circuits</p> <p>EN IEC 61326-1:2021 Electrical equipment for measurement, control, and laboratory use - EMC requirements - Part 1: General requirements</p> <p>EN IEC 61326-2-1:2021 Electrical equipment for measurement, control, and laboratory use - EMC requirements - Part 2-1: Particular requirements for electromagnetic compatibility testing for electrical equipment for measurement, control, and laboratory use</p> <p>EN 50470-3 Electricity metering equipment (a.c.) - Part 3: Particular requirements - Static meters for active energy (class indexes A, B and C)</p>	
防护等级 IP	<p>IP 51 (必须安装在合适的 IP 防护等级外壳中)</p> <p>IP 51 (Must be installed in a suitable IP rated enclosure)</p>	
污染等级 Pollution Degree	II	
UC 等级 UC Degree	III	
安装环境 Installation environment	室内 Indoor use	
保护等级 Protect Degree	II (双重绝缘) Class II (Double Insulation)	
使用环境 usage environment	柜内安装(外壳不可触及) Cabinet mounted(The outer shell cannot be touched)	

机械等级 usage environment	M1
互感器安全特性 Transformer Safety characteristics	<p>绝缘电阻：常态时大于 1000M<math>\Omega</math>； Insulation resistance: greater than 1000 M<math>\Omega</math> under normal conditions;</p> <p>抗电强度：可承受工频 4000V 50Hz/1 分钟； Electric strength resistance: It can withstand 4000V, 50Hz power frequency for 1 minute;</p> <p>阻燃性：符合 UL94-V<sub>0</sub> 级 Flame retardancy: Conforms to UL94-V<sub>0</sub> level;</p>

## 5 外形尺寸

### 5 Overall Dimensions

#### 5.1 仪表尺寸

#### 5.1 Instrument Dimensions

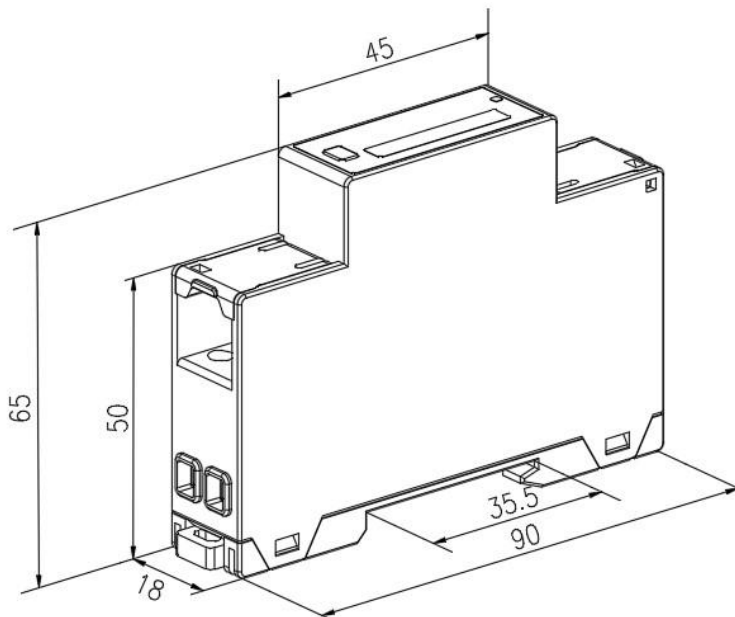

## 5.2 互感器尺寸

## 5.2 Transformer Dimensions

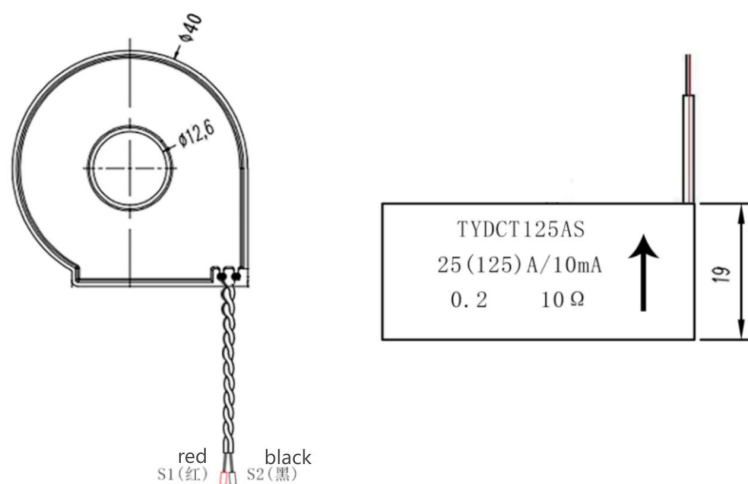

## 6 安全措施

## 6 safety measures

电击、爆炸以及弧光的危险

HAZARD OF ELECTRIC SHOCK, EXPLOSION, OR ARC FLASH

- 请穿戴好人员保护设备 (PPE), 并遵守电气操作安全规程。
- Apply appropriate personal protective equipment (PPE) and follow safe electrical work practices.
- 本产品在使用前不需要试运行。
- This equipment does not require commission before use.
- 开始在本设备上工作之前, 请先关闭本设备及安装有本设备的设备的所有电源。
- Turn off all power supplying this device and the equipment in which it is installed before working on it.
- 务必使用额定电压值正确的电压感应设备, 以确认所有电源均已关闭。
- Always use a properly rated voltage sensing device to confirm that all power is off.
- 切勿超过设备的最高限值。
- Do not exceed the device's ratings for maximum limits.
- 某些关键控制或保护应用中的人身或设备安全依赖于控制电路运行, 请勿将此设备用于此等目的。
- Do not use this device for critical control or protection applications where human or equipment safety relies on the operation of the control circuit.
- 请勿使用水或任何液体材料清洁产品。使用清洁布清除污垢。
- Do not use water or any liquid material to clean the product. Use a cleaning cloth to remove dirt.
- 安装人员负责协调电源侧过流保护装置的额定值和特性与最大额定电流。若违反这些指令将导致死亡或

严重伤害。

• The installer is responsible for co-ordinating the rating and the characteristics of the supply side overcurrent protection devices with the maximum current rating. Failure to follow these instructions will result in death or serious injury.



• 这是安全警示标志，提醒注意潜在的人身伤害危险。当看到此标志时需查阅使用手册。

• This is the safety alert symbol. It is used to alert you to potential personal injury hazards. When seeing this symbol, it is necessary to consult the manual.

## 7 接线与安装

### 7 Connection and Installation

#### 7.1 安装

#### 7.1 Installation

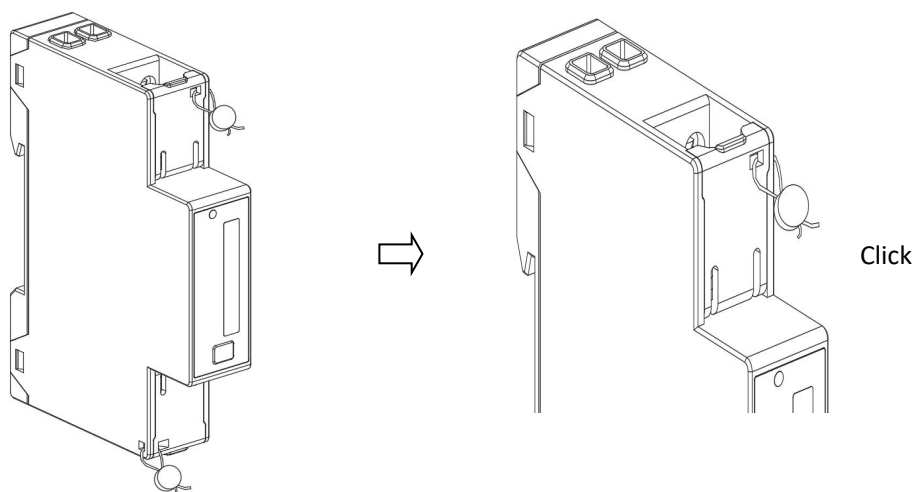
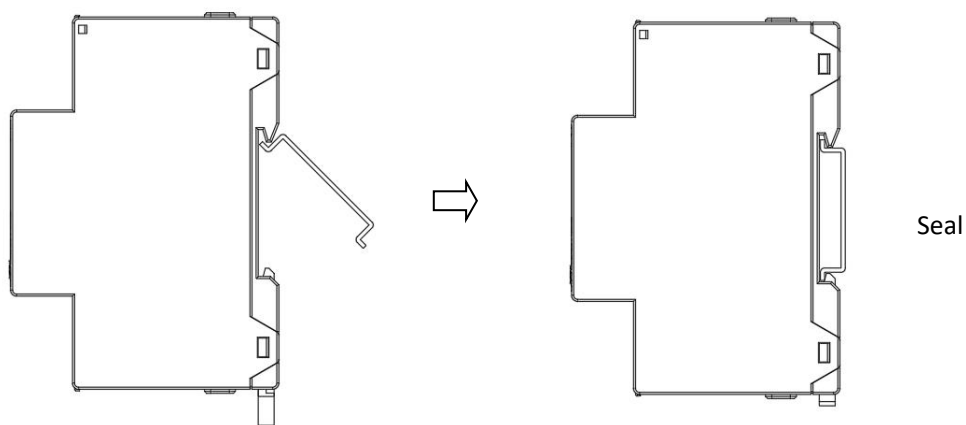

注:

NOTE:

- 1.产品安装完成后需要对翻盖进行铅封;
- 1.Once the product is installed,the flip cover needs to be lead-sealed;
- 2.铅封线不由 Acrel 提供;
- 2.The sealing wires are not provided by Acrel.;
- 3.铅封线的最大直径  $\varnothing \leq 2\text{mm}$ ;
- 3.Max diameter of the sealing wire  $\varnothing \leq 2\text{mm}$ ;

## 7.2 电压电流接线示意图

### 7.2 Schematic Diagram of Voltage and Current Connection

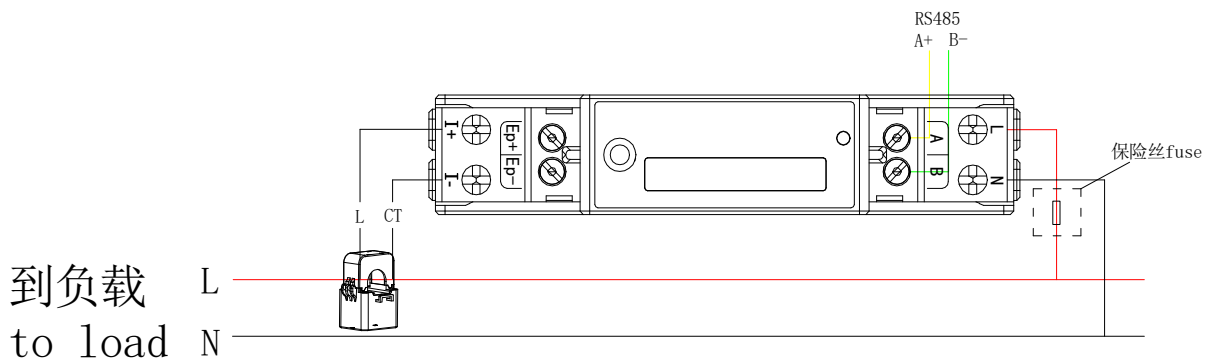

Port	Description	Remark
L	电压线 Voltage Line	
N	中性线 Neutral Line	
I+	电流输入 Current Input	
I-	电流输出 Current output	

- 推荐线径: 2.5...10mm<sup>2</sup> (13...7AWG)
- 所需扭矩为 2N•m (17.7 lb-in)
- Recommended cross section: 2.5...10mm<sup>2</sup> (13...7AWG)
- The necessary torque is 2 N•m (17.7 lb-in) .



### 警告

- 使用额定电压 500V 的铜线
- 连接到现场接线端子的电缆的最低承受温度为 80° C

不遵守以上说明可能会导致死亡、严重伤害和设备损坏



### WARNING

- Use copper wire rated for 500V.
- Minimum temperature rating of the cable to be connected to the field wiring terminals, 80 °C.

**Failure to follow these instructions can result in death, serious injury, or equipment damage.**



## AVERTISSEMENT

- Utilisez un fil de cuivre évalué pour 500V.
- Température nominale minimale du câble à connecter aux bornes de câblage sur le terrain, 80 ° C.

**Le non-respect de ces instructions peut entraîner la mort, des blessures graves ou des dommages à l' équipement.**

注:

Note:

1.出于安全考虑，在电压输入端需接入额定电流 5A 的保险丝；

1.For safety reasons, a fuse with a rated current of 5A needs to be connected to the voltage input terminal;

2.接线之前确保设备处于断电状态；



2.Verify that power is OFF before making connections;

### 7.3 功能性端子

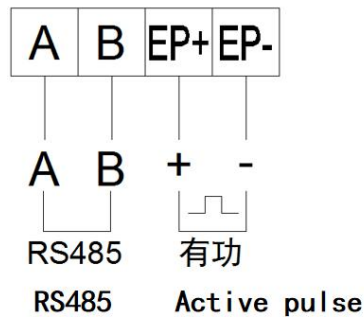
#### 7.3 Functional Terminal



Port	Description	Remark
A	RS485 接口 A RS485 port A	
B	RS485 接口 B RS485 port B	
EP+	脉冲输出+ Active pulse output +	
EP-	脉冲输出- Active pulse output -	

- 推荐线径: 0.25...1.5 mm<sup>2</sup> (26...16 AWG)
- 所需扭矩为 0.5 N•m (4.4 lb-in) .
-  表示双向 RS485 电通讯
- Recommended cross section: 0.25...1.5 mm<sup>2</sup> (26...16 AWG)
- The necessary torque is 0.5 N•m (4.4 lb-in) .
-  means unidirectional RS485 Galvanical port

	<b>警告</b>
<ul style="list-style-type: none"> <li>● 使用额定电压 500V 的铜线</li> <li>● 连接到现场接线端子的电缆的最低承受温度为 80° C</li> </ul> <p><b>不遵守以上说明可能会导致死亡、严重伤害和设备损坏</b></p>	

	<b>WARNING</b>
<ul style="list-style-type: none"> <li>● Use copper wire rated for 500V.</li> <li>● Minimum temperature rating of the cable to be connected to the field wiring terminals, 80 °C.</li> </ul> <p><b>Failure to follow these instructions can result in death, serious injury, or equipment damage.</b></p>	

	<b>AVERTISSEMENT</b>
<ul style="list-style-type: none"> <li>● Utilisez un fil de cuivre évalué pour 500V.</li> <li>● Température nominale minimale du câble à connecter aux bornes de câblage sur le terrain, 80 ° C.</li> </ul> <p><b>Le non-respect de ces instructions peut entraîner la mort, des blessures graves ou des dommages à l' équipement.</b></p>	

## 8 主要功能特点

### 8 Main Functional Features

#### 8.1 测量功能

##### 8.1 Measurement Function

能测量全电力参数包括电压 U、电流 I、有功功率 P、无功功率 Q、视在功率 S、功率因数 PF、频率。其中电压 U 保留 1 位小数，频率 F 保留 2 位小数，电流 I 保留 2 位小数，功率 P 保留 3 位小数。

It can measure total power parameters including voltage U, current I, active power P, reactive power Q, apparent power S, power factor PF and frequency. Wherein, the voltage U is reserved with 1 decimal place, the frequency F is reserved with 2 decimal places, the current I is reserved with 2 decimal places, and the power P is reserved with 3 decimal places.

如:  $U = 220.1V$ ,  $f = 49.98Hz$ ,  $I = 1.99A$ ,  $P = 0.439kW$

For example,  $U = 220.1V$ ,  $f = 49.98Hz$ ,  $I = 1.99A$ ,  $P = 0.439kW$

仪表同时提供以上电参量高速响应寄存器，见第 9 章通讯说明。

The above electrical parameter high-speed response registers are also provided with the instrument, see Chapter 9 "Communication Instructions".

#### 8.2 计量功能

##### 8.2 Metering Function

能计量当前组合有功电能，正向有功电能，反向有功电能，正向无功电能，反向无功电能。

It can measure the current combined active electric energy, forward active electric energy, reverse active electric energy, forward reactive electric energy and reverse reactive electric energy.

## 9 操作与显示

### 9 Operation and Display

#### 9.1 按键功能说明

##### 9.1 Key Function Description

表 4 指示灯说明

Table 2 Explanation of Indicator Lights

指示灯名称 Indicator name	说明 illustrate
E	脉冲指示灯，如脉冲常数是 600 时，每个脉冲表示 1/600kwh 电量 Pulse indicator light, if the pulse constant is 600, each pulse represents 1/600kwh of electricity



## 9.2 显示界面

## 9.2 Display Interface

ADL200N:

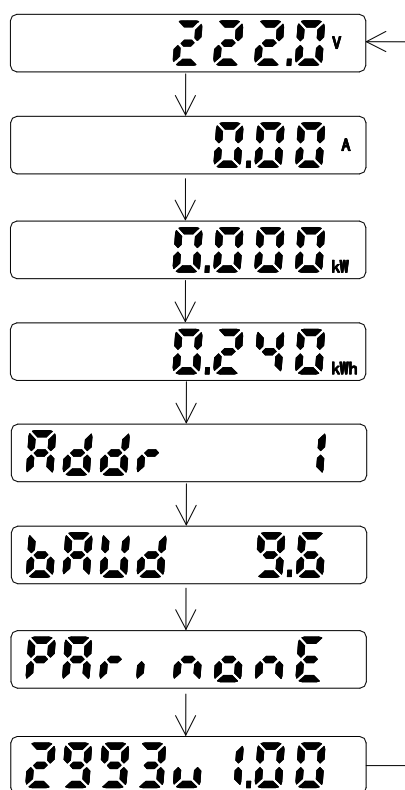

可通过按键切换页面或自动循环显示页面  
The interface can be switched by pressing the key or the interface can be displayed automatically and circularly

## 10 通信说明

## 10 Communication Instructions

仪表RS485通信接口支持MODBUS-RTU通信协议,通信口波特率可在1200bps、2400bps、4800bps、9600bps、19200bps和38400bps之间设置,校验位为无校验。

The instrument RS485 communication interface supports MODBUS-RTU communication protocol. The baud rate of communication interface can be set between 1,200bps, 2,400bps, 4,800bps, 9,600bps, 19,200bps and 38,400bps, and the check bit is no check.

仪表的RS485通信口要求使用屏蔽双绞线连接,布线时要考虑整个网络的布局:如通信线缆的长度、走向、上位机的位置、网络末端的匹配电阻、通信转换器、网络可扩展性、网络覆盖范围、环境的电磁干扰情况等因素,都要综合考虑。

The RS485 communication interface of the instrument requires shielded twisted pair connection, and the layout of the whole grid should be considered when wiring: For example, the length and direction of communication cable, the position of upper computer, the matching resistance at the end of the grid, the communication converter, the scalability of the grid, the coverage of the grid, the electromagnetic interference of the environment and other factors should be considered comprehensively.

注:

Note:

- 1、在布线工程上要严格按照要求施工;

1. It shall strictly construct according to the requirements in the wiring project;
- 2、对于暂时不需要通信的仪表都要将他们连接到 RS-485 网络上，以便于诊断和测试；
2. For instruments that do not need communication temporarily, they should be connected to RS-485 grid for diagnosis and test;
- 3、进行 RS-485 电缆连接时，尽量使用双色双绞线，所有的 485 通信口“A”端接同一种颜色，“B”端接另一种颜色。
3. When connecting RS-485 cable, try to use two-color twisted pair. All 485 communication ports "A" are terminated in the same color, and "B" is terminated in another color.
- 4、RS-485 总线(从上位机通信口开始到任一被连接的仪表终端通信口)长不超过 1000 米。
4. The length of RS-485 bus (from the communication interface of the upper computer to any connected instrument terminal communication interface) shall not exceed 1,000 meters.

## 10.1 地址表

### 10.1 Address Table

仪表支持 MODBUS-RTU 协议中的 03H 命令与 10H 命令，03H 为读多个寄存器，10H 为写多个寄存器，协议数据格式请自行查询。下表为仪表的寄存器地址表：

Meter supports 03H command and 10H command in MODBUS-RTU protocol, in which 03H for reading multiple registers and 10H for writing multiple registers. Please check the protocol data format by yourself. The following table is the register address table of the meter:

表 5 通讯地址表

Table 5 Communication Address Table

地址 Address	名称 Name	R/W	字长 Length (Bytes)	类型 Type	单位 Unit	备注 Note
1000H	地址 slave address	R/W	1	uint16		1-247
1001H	波特率 baud rate	R/W	1	uint16		1200, 2400, 4800, 9600, 19200, 38400,
1002H	校验位 parity	R/W	1	uint16		低字节 0: 无校验 None 1: 奇校验 Odd 2: 偶校验 Even 高字节 0: 1 停止位 1stop 1: 1.5 停止位 1.5stop 2: 2 停止位 2stop
1010H	网络选择 Grid	R/W	1	uint16		0:3P4L 1:3P3L
1011H	电压二次额定值 rated second voltage	R/W	1	uint16	0.1V	0.1-999.9V
1012H	电流二次额定值 rated second current	R/W	1	uint16	0.01A	0.01-999.99A
1015H	电压一次额定值 rated primary voltage	R/W	1	uint32	0.1V	0.1-99999.9V
1017H	电流一次额定值 rated primary current	R/W	1	uint32	0.01A	0.01-9999.99A

101DH	密码 Password	R/W	1	uint16		1-9999
101EH	脉冲常数 Pulse constant	R/W	1	uint16		1-99999
101FH	电压屏蔽 Voltage shielding value	R/W	1	uint16	0.01%	
1020H	电流屏蔽 Current shielding value	R/W	1	uint16	0.01%	
1023H	上电默认界面 Power-on default interface	R/W	1	uint16		0: 自动轮显 0: Automatic wheel display 其他: 其他界面 Others: Other interfaces
1035H	视在功率计算方式 Apparent power calculation mode	R/W	1	uint16		0: RMS 1: PQS
2000H	A 相电压 A-phase voltage	R	2	float	V	1.慢速寄存器 1.Slow register 2.ADL200N 只有 A 相数据 2.ADL200N only has A-phase data
2002H	B 相电压 B-phase voltage	R	2	float	V	
2004H	C 相电压 C-phase voltage	R	2	float	V	
2006H	AB 线电压 AB-line voltage	R	2	float	V	
2008H	BC 线电压 BC-line voltage	R	2	float	V	
200AH	CA 线电压 CA-line voltage	R	2	float	V	
200CH	A 相电流 A-phase current	R	2	float	A	
200EH	B 相电流 B-phase current	R	2	float	A	
2010H	C 相电流 C-phase current	R	2	float	A	
2012H	N 线电流 N-phase current	R	2	float	A	
2014H	A 相有功功率 A-phase active power	R	2	float	kW	
2016H	B 相有功功率 B-phase active power	R	2	float	kW	
2018H	C 相有功功率 C-phase active power	R	2	float	kW	
201AH	总有功功率 Total active power	R	2	float	kW	
201CH	A 相无功功率 A-phase reactive power	R	2	float	Kvar	
201EH	B 相无功功率 B-phase reactive power	R	2	float	Kvar	
2020H	C 相无功功率 C-phase reactive power	R	2	float	Kvar	
2022H	总无功功率 total reactive power	R	2	float	Kvar	
2024H	A 相视在功率 A-phase apparent power	R	2	float	KVA	
2026H	B 相视在功率 B-phase apparent power	R	2	float	KVA	
2028H	C 相视在功率	R	2	float	KVA	

	C-phase apparent power					
202AH	总视在功率 Total apparent power	R	2	float	KVA	
202CH	A 相功率因数 A-phase power factor	R	2	float		
202EH	B 相功率因数 B-phase power factor	R	2	float		
2030H	C 相功率因数 C-phase power factor	R	2	float		
2032H	总功率因数 Total power factor	R	2	float		
2034H	频率 Frequency	R	2	float	Hz	
2100H	A 相电压 A-phase voltage	R	2	float	V	
2102H	B 相电压 B-phase voltage	R	2	float	V	
2104H	C 相电压 C-phase voltage	R	2	float	V	
2106H	AB 线电压 AB-line voltage	R	2	float	V	
2108H	BC 线电压 BC-line voltage	R	2	float	V	
210AH	CA 线电压 CA-line voltage	R	2	float	V	
210CH	A 相电流 A-phase current	R	2	float	A	
210EH	B 相电流 B-phase current	R	2	float	A	
2110H	C 相电流 C-phase current	R	2	float	A	
2112H	N 线电流 N-phase current	R	2	float	A	
2114H	A 相有功功率 A-phase active power	R	2	float	kW	
2116H	B 相有功功率 B-phase active power	R	2	float	kW	
2118H	C 相有功功率 C-phase active power	R	2	float	kW	
211AH	总有功功率 Total active power	R	2	float	kW	
211CH	A 相无功功率 A-phase reactive power	R	2	float	Kvar	
211EH	B 相无功功率 B-phase reactive power	R	2	float	Kvar	
2120H	C 相无功功率 C-phase reactive power	R	2	float	Kvar	
2122H	总无功功率 total reactive power	R	2	float	Kvar	
2124H	A 相视在功率 A-phase apparent power	R	2	float	KVA	
2126H	B 相视在功率 B-phase apparent power	R	2	float	KVA	
2128H	C 相视在功率 C-phase apparent power	R	2	float	KVA	

1.快速寄存器  
(响应时间≤100ms)  
1.Slow register  
(response rate ≤100ms)  
2.ADL200N 只有 A 相数据  
2.ADL200N only has A-phase data

212AH	总视在功率 Total apparent power	R	2	float	KVA	
212CH	A 相功率因数 A-phase power factor	R	2	float		
212EH	B 相功率因数 B-phase power factor	R	2	float		
2130H	C 相功率因数 C-phase power factor	R	2	float		
2132H	总功率因数 Total power factor	R	2	float		
2134H	频率 Frequency	R	2	float	Hz	
3000H	总有功电能一次值 active electric energy	R	4	double	kWh	
3004H	正向有功电能一次值 forward active electric energy	R	4	double	kWh	
3008H	反向电能一次值 reverse active electric energy	R	4	double	kWh	
300CH	总无功电能一次值 reactive electric energy	R	4	double	kVarh	
3010H	正向无功电能一次值 forward reactive electric energy	R	4	double	kVarh	
3014H	反向无功电能一次值 reverse reactive electric energy	R	4	double	kVarh	
3018H	视在电能一次值 apparent electric energy	R	4	double	kVAh	

## 11 常见故障分析

### 11 Common Fault Analysis

#### 11.1 显示故障（电压电流功率显示异常）

##### 11.1 Display Fault (Abnormal Voltage, Current, and Power Indications)

(1)检查：实际接线与接线图的要求是否相同，注意电压线序是否正确，电流互感器的套线方向和相序是否正确；

(1) Inspection: Check whether the actual wiring is the same as the requirements of the wiring diagram, pay attention to whether the voltage wiring order is correct, and whether the direction of the current transformer's secondary winding and phase sequence are correct.

(2)测量：若接线没有问题，采用万用表通断测试档对产生问题所相关的外部线路接线进行测量，查看外部线路的端子与仪表端子之间是否导通。

(2) Measurement: If the wiring is correct, use a multimeter in continuity test mode to measure the external circuit connections related to the problem. Check for continuity between the terminals of the external circuit and the instrument terminals.

注意：在查看电流和电压线路时，一定要确保信号电流和电压处于断开状态，保证人身安全。

Note: When inspecting current and voltage circuits, ensure that the signal current and voltage are disconnected to ensure personal safety.

#### 11.2 通讯故障

##### 11.2 Communication Fault

(1)检查：查看仪表的通信设置信息如通信地址、波特率、校验方式与上位机的设置是否一致。

(1) Inspection: Verify that the communication settings of the instrument, such as the communication address, baud rate, and parity check, match the settings of the master device.

(2)检查：检查通讯接线是否正确，A、B 是否接反。

(2) Check if the communication wiring is correct and if A and B are connected incorrectly.

## 12 运输与贮存

### 12 Transportation and Storage

仪表的包装宜采用符合环保要求的材料，仪表及附件在包装条件下应贮存在通风干燥处，避免受潮和腐蚀气体的浸蚀，贮存的极限环境温度为 $-40^{\circ}\text{C}\sim+80^{\circ}\text{C}$ ，相对湿度不超过 75%。

The packaging of the instrument should use environmentally friendly materials. The instrument and its accessories, when packaged, should be stored in a ventilated and dry place to avoid moisture and corrosion by gases. The storage temperature should be between  $-40^{\circ}\text{C}$  and  $+80^{\circ}\text{C}$ , with a relative humidity not exceeding 75%.

## 13. 保修与服务

### 13. Warranty and Service

制造厂对产品质量实行三包，仪表自出厂之日起 24 个月内，用户在完全遵守本说明书的规定的使用条件下，使用时发现仪表损坏，由本公司负责免费修理或更换。

The manufacturer offers a triple guarantee on product quality. Within 24 months from the date of manufacture, if the user fully complies with the usage conditions specified in this manual and finds the instrument damaged during use, our company will be responsible for repairing or replacing it free of charge.

总部：安科瑞电气股份有限公司

Headquarter: Acrel Co., LTD.

地址：上海市嘉定区育绿路 253 号

Address: No.253 Yulv Road Jiading District, Shanghai, China

邮编：201801

Postcode: 201801

生产基地：江苏安科瑞电器制造有限公司

Manufacturer: Jiangsu Acrel Electrical Manufacturing Co., LTD.

地址：江苏省江阴市南闸街道东盟工业园区东盟路 5 号

Address: No.5 Dongmeng Road,Dongmeng industrial Park, Nanzha Street,Jiangyin City,Jiangsu Province,China

电话/WhatsApp: 0086-188 6162 8731

TEL/WhatsApp: 0086-188 6162 8731

网址： [www.acrel-electric.uk/](http://www.acrel-electric.uk/)

Web-site: [www.acrel-electric.uk/](http://www.acrel-electric.uk/)

邮箱： [elsie.ren@email.acrel.cn](mailto:elsie.ren@email.acrel.cn)

Email: [elsie.ren@email.acrel.cn](mailto:elsie.ren@email.acrel.cn)

邮编：214405

Postcode: 214405