

350



ADW300 Wireless Metering Meter

Installation and Use Manual V1.5

Acrel Electric Co., Ltd.

Declaration

The copyright is the property of Acrel. Any information in any paragraph or section cannot be extracted, copied or otherwise reproduced or propagated. Otherwise offenders shall take all consequences.

All rights are reserved.

Acrel reserves the right to modify the product specifications herein without notification. Please consult the local agent about the latest specifications before placing a purchase order.

Contents

Declaration	1
1 Overview	1
2 Product model and specification	1
2.1 Naming Rules	1
2.1.1 ADW300 Wireless Metering Meter	1
2.1.2 Adw300-hj wireless meter naming rules	1
2.2 Functional Characteristics	2
3 Technical parameter	2
3.1 Electrical performance	2
3.2 Work environment	3
4 Dimension and installing description	3
4.1 Dimension (Unit: mm)	3
4.2 Interfaces of Auxiliary power supply, Communication and Pulse	6
4.3 Interfaces of DI and DO	6
4.4 Interfaces of Temperature and Aftercurrent	7
4.5 Instruction of wiring	7
4.5.1 ADW300	8
4.5.2 ADW300W	9
5 Main functions and features	10
5.1 Measurement	10
5.2 Metering	10
5.3 Tiered pricing	11
5.4 Demand	11
5.5 Historical data	11
5.6 Digital input/ output	11
5.7 Wireless Communication Function	11
6 Communication description	11
6.1 Protocol	11
6.2 MODBUS	12
6.3 Alarm function related Settings	22

6.3.1 Alarm 1 related parameter register address table	22
6.3.2 Alarm 2, alarm 3 related parameter register address table	25
6.4 Primary Value Address Table	29
6.5 Historical Data Memory	42
6.6 Record of extreme value and occurrence time	43
7 Common troubleshooting	46

1 Overview

ADW300 Wireless Metering Meter is mainly used to metering three phase active energy on low voltage network. The product boasts of advantages including compact size, high precision, rich features. According to different requirements, there are many communications functions like RS485 communication,lora,NB,4G,WIFI adding the new current sampling mode using external transformer. It can be flexibly installed in the distribution box to achieve sub-item electric energy metering, operation and maintenance supervision or power monitoring requirements for different regions and different loads.

2 Product model and specification

2.1 Naming Rules

2.1.1 ADW300 Wireless Metering Meter

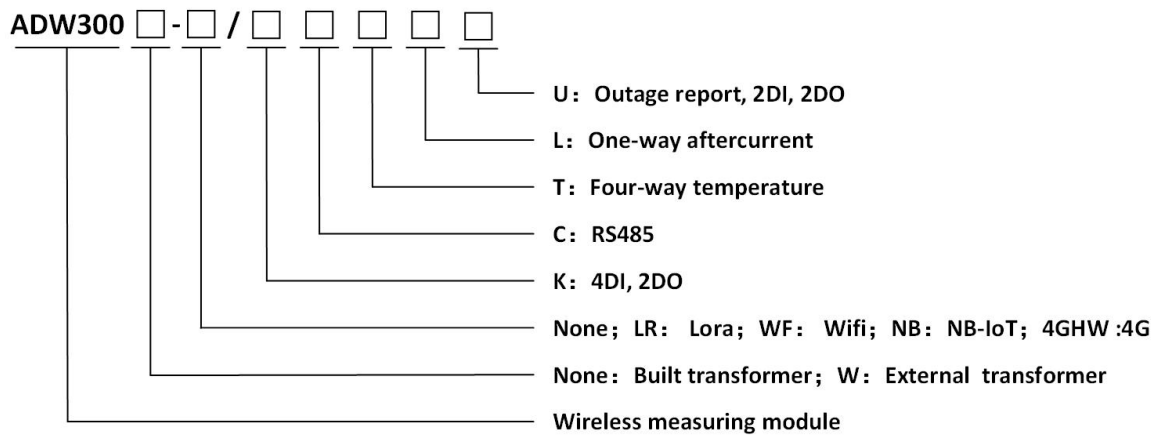

2.1.2 Adw300-hj wireless meter naming rules

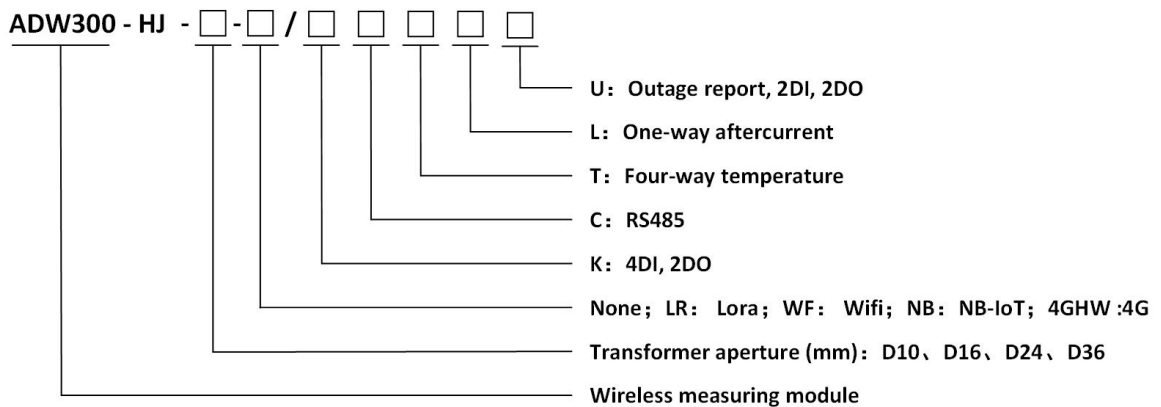

2.2 Functional Characteristics

Chart 1 Functions of ADW300

Functions	Description
Display mode	LCD
Energy metering	Active kWh (positive and negative), quadrant reactive power energy
Electrical measurement	U、I、 P、 Q、 S、 PF、 F
Harmonic function	THDv、 Harmonic on 2nd-31st
Pulse output	Active pulse output
Three-phase unbalance degree	Voltage unbalance,current unbalance
Temperature measurement	Temperature of A/B/C/N (Alternate configuration:T)
DI/DO	4DI,2DO (Alternate configuration:K)
Aftercurrent	One-way aftercurrent (Alternate configuration:L)
LED display	Pulse LED display
External current transformer	External open type current transformer (Alternate configuration:W)
Electrical parameter	Undervoltage, undercurrent, overcurrent, underload, etc
Communication	Infrared communication
	RS485 (Alternate configuration:C)
	Wireless transmission on 470MHz (Alternate configuration:LR)
	GPRS (Alternate configuration:2G)
	NB-IOT (Alternate configuration:NB)
	4G (Alternate configuration:4GHW)
	WIFI (Alternate configuration:WF)

3 Technical parameter

3.1 Electrical performance

Chart 2 Electrical performance of ADW300

Voltage input	Rated voltage	$3 \times 57.7/100V, 3 \times 220/380V, 3 \times 380/660V, 3 \times 100V, 3 \times 380V, 3 \times 660V$
	Reference frequency	50Hz

	Consumption	<0.5VA (Each phase)
Current input	Input current	3×1(6)A ; 3×1(6)A (ADW300W) , 3×20(100)A (ADW300W) -HJ: (3×1.5(6)A (D10) 、3×20(100)A (D16) 、3×80(400)A (D24) 、 3×120(600)A (D36))
	Start current	1‰ Ib (Class 0.5S), 4‰ Ib (Class 1)
	Consumption	<1VA (Each phase)
Auxiliary power	Power Supply	AC 85~265V, DC 12V
	Power consumption	<2W
Measurement performance	Standard	IEC 62053-22:2003, IEC 62053-21:2003
	Active energy accuracy	Class 0.5S (ADW300) , Class 1 (ADW300W)
	Temperature accuracy	±2℃
Pulse	Width of pulse	80±20ms
	Pulse constant	6400imp/kWh , 400imp/kWh -HJ (6400imp/kWh (D10) 、400imp/kWh (D16) 、100imp/kWh (D24) 、60imp/kWh (D36))
Communication	Wireless	Transmission on 470MHz and maximum distance in open space is 1km; 2G; NB; 4G; WIFI
	Infrared communication	The constant baud rate is 1200
	Interface	RS485(A、B)
	Connection mode	Shielded twisted pair conductors
	Protocol	MODBUS-RTU

3.2 Work environment

Chart 3 Work environment

Temperature range	Operating temperature	-20℃~55℃
	Storage temperature	-40℃~70℃
	Humidity	≤95% (No condensation)
	Altitude	<2000m

4 Dimension and installing description

4.1 Dimension (Unit: mm)

(1) Dimensions of ADW300

Chart 4 Dimension of Residual Current transformer

Specifications	Current Rating	Inside diameters Φ mm	Outside diameters Φ mm	Weight
----------------	----------------	--------------------------	---------------------------	--------

AKH-0.66L45	16~100A	45	76	0.18
AKH-0.66L80	100~250A	80	120	0.42
AKH-0.66L100	250~400A	100	140	0.50
AKH-0.66L150	400~800A	150	190	1.32
AKH-0.66L200	800~1500A	200	240	1.94

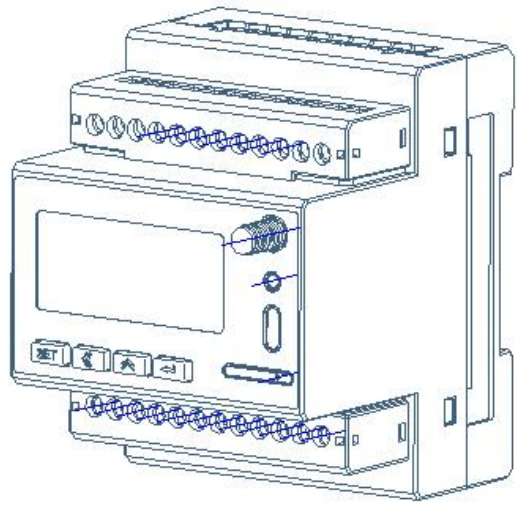

Figure 1 Rendering of ADW300

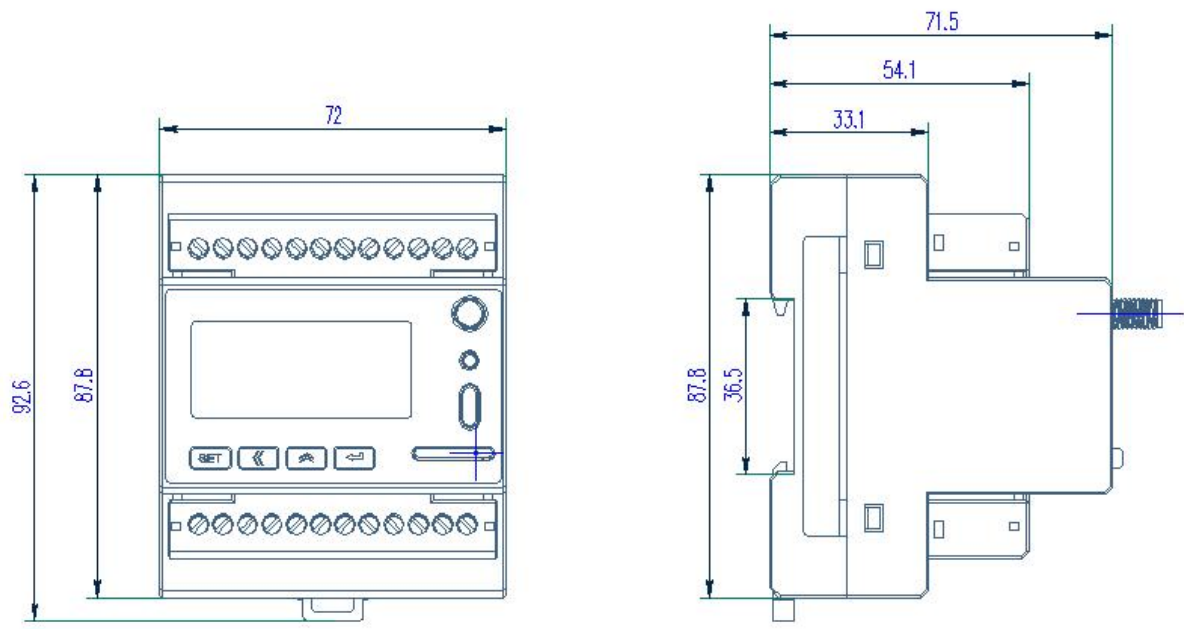

Figure 2 Dimension of ADW300

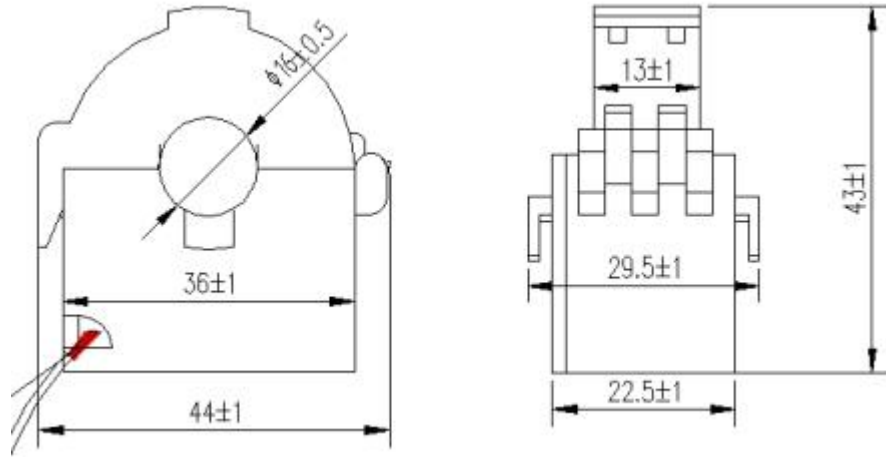
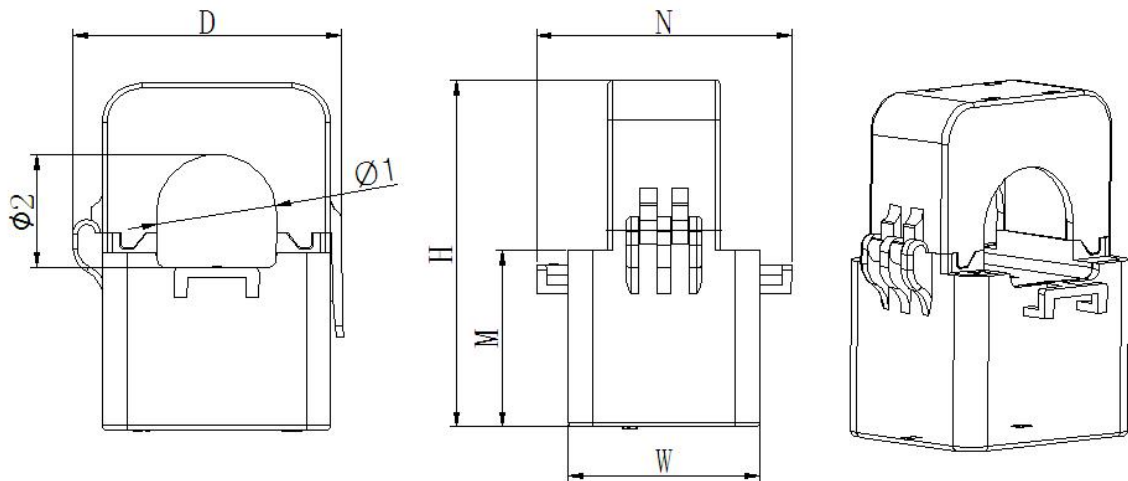

Figure 3 Dimension of transformer HCT16K-FJ

(2) Dimensions of ADW300-HJ

Chart 5 Dimension of Current transformer

Specifications	external dimension (mm)					Hole size (mm)		error range (mm)
	W	H	D	M	N	Φ1	Φ2	
AKH-0.66/K-∅ 10N	2	4	32	25	36	10	9	±1
AKH-0.66/K-∅ 16N	3	5	36	27	42	16	17	
AKH-0.66/K-∅ 24N	3	7	46	36	52	24	23	
AKH-0.66/K-∅ 36N	4	8	58	40	56	33	35	



Dimension drawing of supporting transformer

4.2 Interfaces of Auxiliary power supply, Communication and Pulse

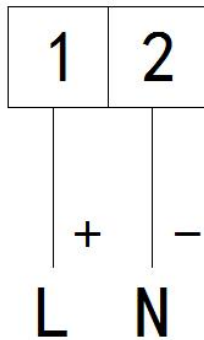

Auxiliary power supply Interface

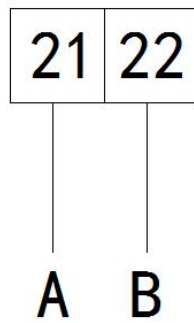

Communication Interface

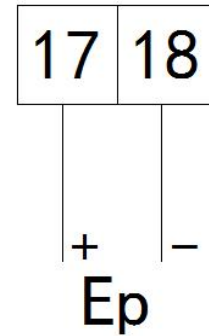

Pulse Interface

4.3 Interfaces of DI and DO

The digital output is realized by relay for remote control and alarm output.

The digital input is realized by digital signal input. The meter has a built-in +12V working power supply so that it does not require external power supply. The meter collects the external break-make information with digital input module and displays it locally. The digital input not only collects and displays the local break-time information but also provides the remote transmission, i.e. remote communication, with RS485.

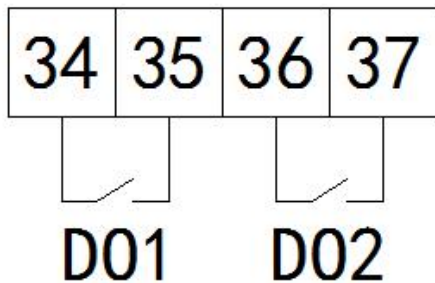

Digital output

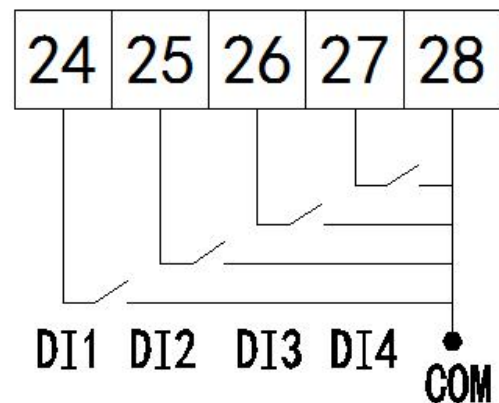

Digital input

4.4 Interfaces of Temperature and Aftercurrent

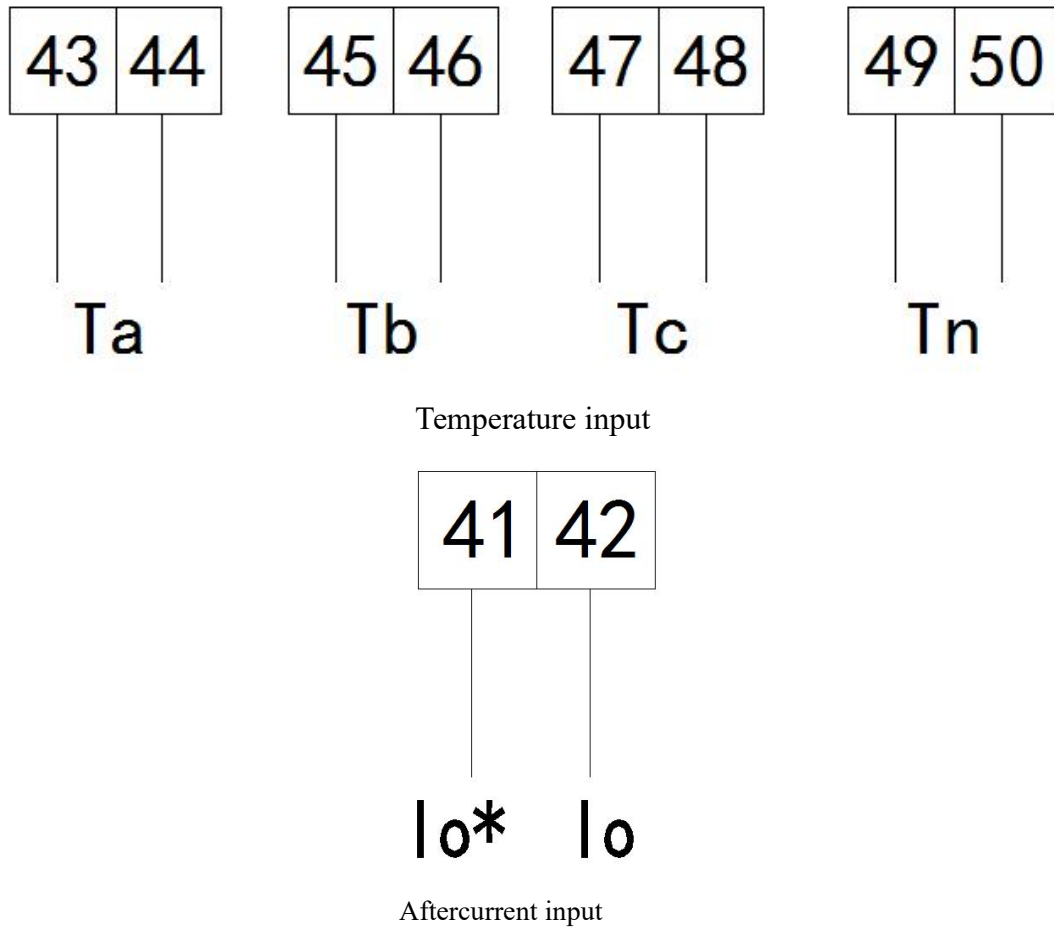

4.5 Instruction of wiring

There are four modes of connection like 3-phase 4-wire (current connected via CT), 3-phase 3-wire (current connected via CT), 3-phase 4-wire (current connected via PT and CT) and 3-phase -wire (current connected via PT and CT).

Remark:

1. The ADW300W external transformer has two red and white wires, red connected to instrument I_A^* , I_B^* , I_C^* , white connected to instrument I_A , I_B , I_C ; The ADW300-HJ external transformer has two red and black wires, red connected to instrument I_A^* , I_B^* , I_C^* , and black connected to instrument I_A , I_B , I_C ;

2. Transformers of ADW300W and ADW300-HJ are with mA output, 5A or 1A output transformer is not allowed connected to the energy meters, otherwise energy meters will be damaged;

3. Neither Short-circuit nor ground connection to energy meters ADW300W (ADW300-HJ) is allowed, otherwise energy meters will be inaccurate or even damaged;

4. When incoming current through the existing transformer output, the existing transformer needs to be kept away from the transformer belonging to ADW300W or

ADW300-HJ (>30cm) so as to avoid interference.

4.5.1 ADW300

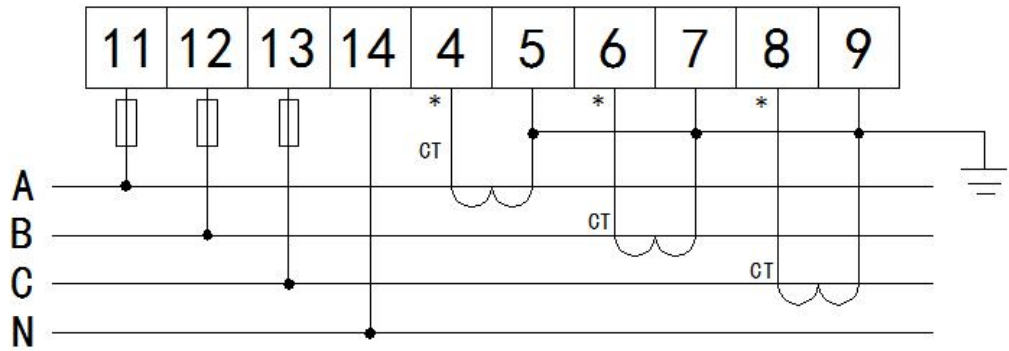

3-phase 4-wire (current connected via CT)

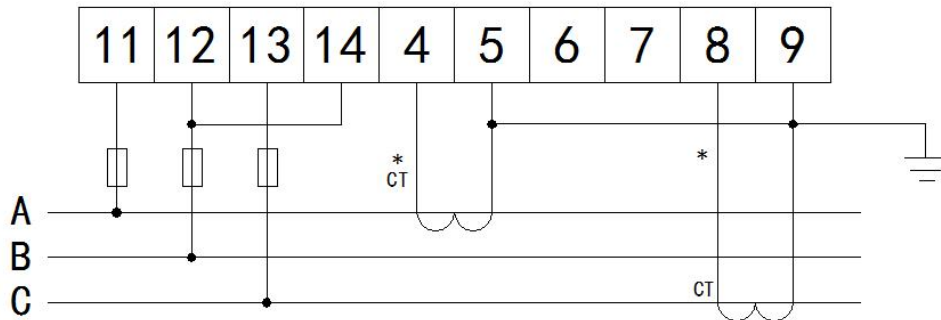

3-phase 3-wire (current connected via CT)

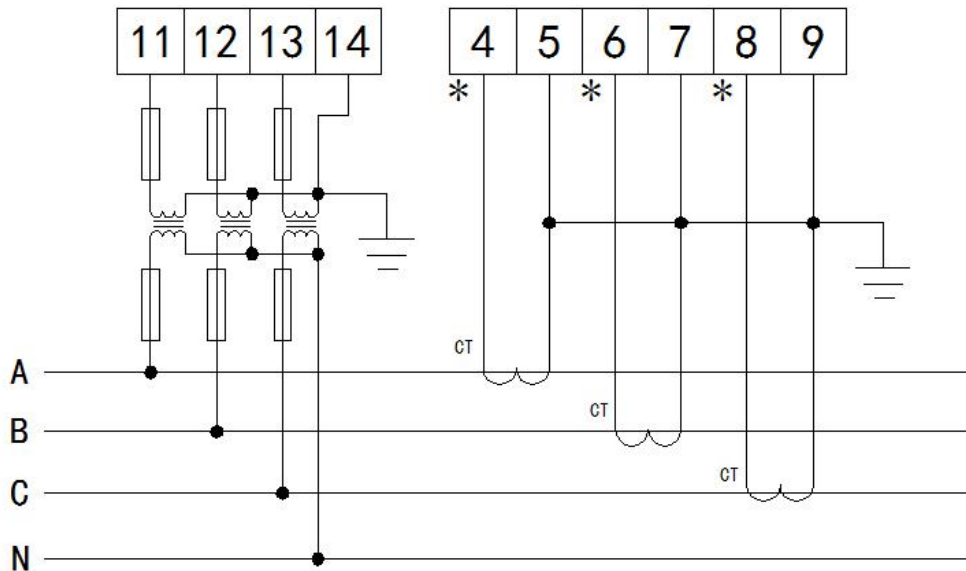

3-phase 4-wire (current connected via PT and CT)

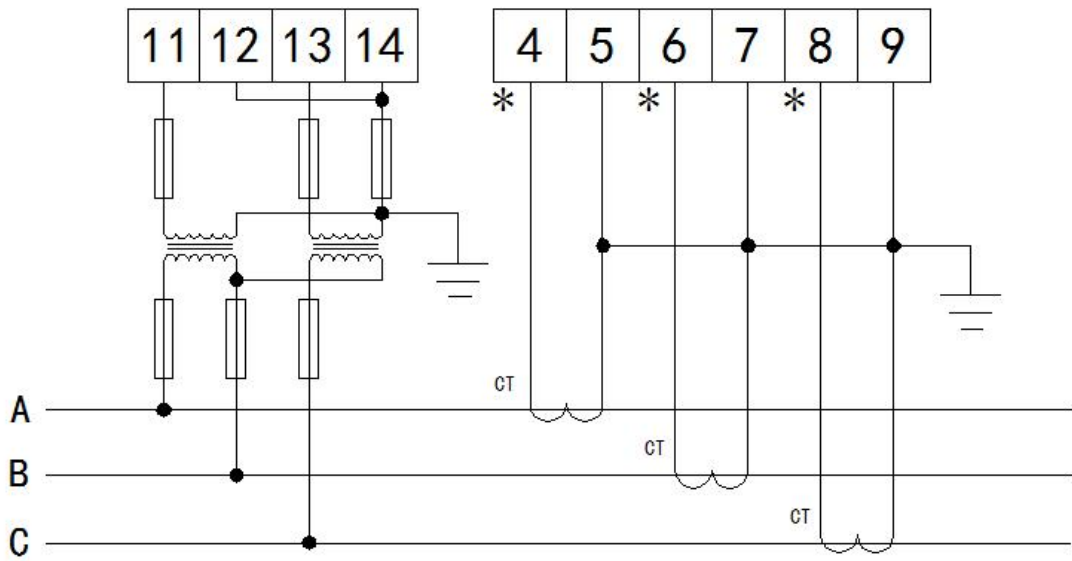

3-phase 3-wire (current connected via PT and CT)

4.5.2 ADW300W

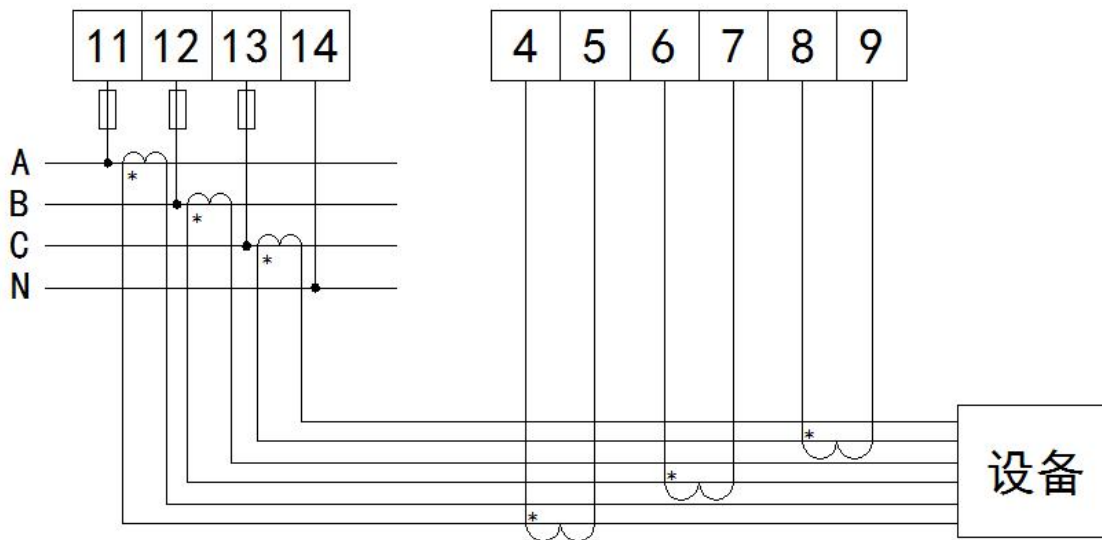

3-phase 4-wire

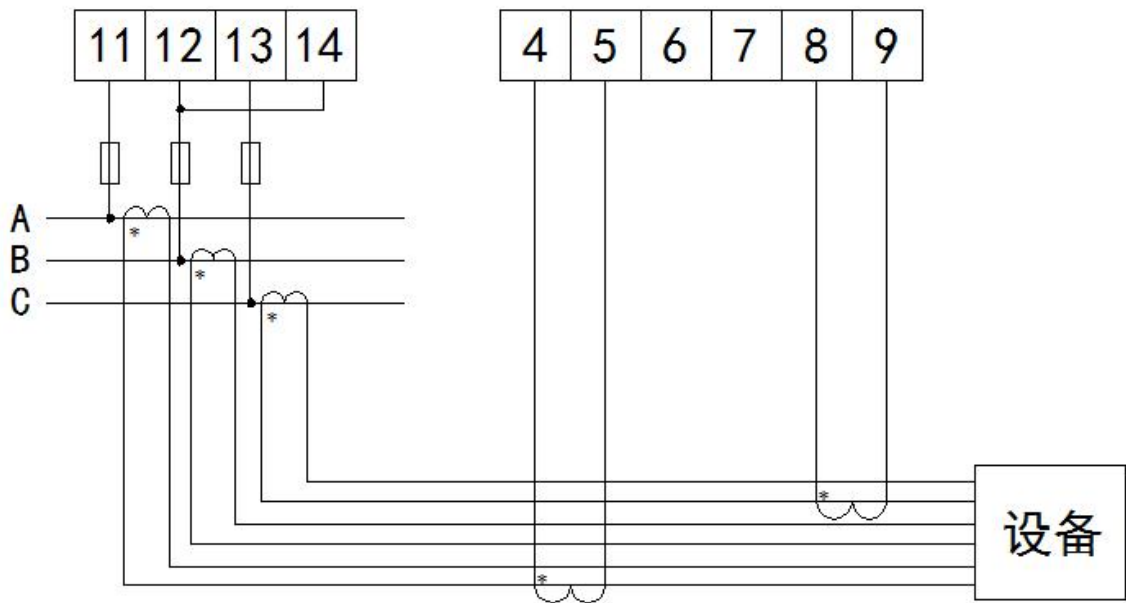

3-phase 3-wire

5 Main functions and features

5.1 Measurement

Measure all electrical parameters, including voltage U, current I, active power P, reactive power Q, apparent power S, power factor PF, Voltage imbalance, Current imbalance, frequency, 31st harmonic content and total harmonic content . The measured voltage U keeps one decimal place, the measured frequency F keeps two decimal places, the measured current I keeps three decimal places and the measured power P keeps four decimal places. Voltage imbalance and Current imbalance keeps four decimal places.

Example: $U = 220.1V$, $f = 49.98HZ$, $I = 1.999A$, $P = 0.2199KW$, $\Delta = 0.00\%$

Supporting 4-way temperature measurement, range: $-40\sim 99^{\circ}C$, accuracy: $\pm 2^{\circ}C$

Supporting aftercurrent measurement, The initial range: $0\sim 1000mA$, Range multiples can be set (1~60)

5.2 Metering

It can measure the current combined active power, positive active power, reverse active power, inductive reactive power, capacitive reactive power, as seen in the electric power.

5.3 Tiered pricing

Two sets of time tables, a year can be divided into four time zones, each set of time table can set 12 days, four rates (F1, F2, F3, F4 namely Sharp, peak, flat and valley).

5.4 Demand

Demand-related concepts are listed as follows:

Demand	Average power measured during the demand period
Max. demand	Maximum amount of demand during a specified period of time
Sliding window time	A recurrence method to measure the demand from any time point during a period shorter than the demand period. The demand measured by this means is called sliding demand. The recurrence time is sliding window time.
Demand period	Time interval when the same average power is measured continuously, also known as window time

Measure eight maximum demands, i.e. A/B/C three-phase current ,positive active, negative active, inductive reactive , capacitive reactive and apparent power demands and the time of maximum demand.

5.5 Historical data

Record the historical data on electricity consumption covering previous 12 months (including four quadrant and multi-rate tariff).

5.6 Digital input/ output

There are two-way Digital output and four-way Digital input. The Digital output is realized by relay for remote control and alarm output. The Digital input not only collects and displays the local break-time information but also provides the remote transmission, i.e. remote communication, with RS485.

5.7 Wireless Communication Function

ADW300 supports RS485 communication, LORA communication, NB, 4G and Wifi communication. For the specific protocols of NB, 4G and Wifi communication, please contact the relevant personnel of our company.

6 Communication description

6.1 Protocol

The meters adapt Modbus protocol. Please refer to the relevant standards for more

information.

6.2 MODBUS

MODBUS-RTU protocol has 03H and 10H command to read and write registers respectively. The following chart is registers' address list:

Start Address (Hexadecimal)	Start Address (Decimal)	Variable	Length	R/W	Notes
0000H	0	Address	2	R/W	1~247
0001H	1	Baud rate	2	R/W	1: 1200bps 2: 3400bps 3: 4800bps 4: 9600bps
0002H	2	Spreading factor	2	R/W	6~12
0003H	3	Frequency channel setting	2	R/W	0-45 (Communication with the same frequency host)
0004H	4	High byte: parity mode, low byte: stop Bit	2	R/W	High byte: 0-none, 1-even, 2-odd; low byte: 0- 1 stop Bit, 1- 2 stop Bit
0005H-0006H	5-6	Reserved			
0007H	7	Backlight Time			
0008H	8	Code			
0009H~000CH	9-13	Reserved			
000EH	14	PT			
000FH	15	CT			
0010H	16	Temperature of N phase	2	R	Int16 unit 0.1°C If the reading value is 105, the temperature is 10.5°C
0011H~0013H	17-19	Time, date (second, minute, hour, day, month, year)			
0014H	20	Voltage of A phase	2	R	Uint16 1 decimal places (The real value is the showed value divide 10.The following data all in this rule.)
0015H	21	Voltage of B phase	2	R	
0016H	22	Voltage of C phase	2	R	
0017H	23	Voltage between A-B	2	R	
0018H	24	Voltage between B-C	2	R	
0019H	25	Voltage between C-A	2	R	
001AH	26	Current of A	2	R	Uint16

		phase			unit A 2 decimal places
001BH	27	Current of B phase	2	R	
001CH	28	Current of C phase	2	R	
001DH	29	Vector sum of 3-phase current	2	R	
001EH	30	Active power of A phase	4	R	Int32 unit kW 3 decimal places
0020H	32	Active power of B phase	4	R	
0022H	34	Active power of C phase	4	R	
0024H	36	Total active power	4	R	
0026H	38	Reactive power of A phase	4	R	Int32 unit kVar 3 decimal places
0028H	40	Reactive power of B phase	4	R	
002AH	42	Reactive power of C phase	4	R	
002CH	44	Total reactive power	4	R	
002EH	46	Apparent power of A phase	4	R	Uint32 unit kVA 3 decimal places
0030H	48	Apparent power of B phase	4	R	
0032H	50	Apparent power of C phase	4	R	
0034H	52	Total apparent power	4	R	
0036H	54	Power factor of A phase	2	R	Uint16 3 decimal places
0037H	55	Power factor of B phase	2	R	
0038H	56	Power factor of C phase	2	R	
0039H	57	Total power factor	2	R	

003AH	58	State of DI	2	R	Uint16 Bit0: DI1 Bit1: DI2 Bit2: DI3 Bit3: DI4
003BH	59	Frequency of power	2	R	Uint16 2 decimal places
003CH	60	Total energy consumption	4	R	Uint32 unit kWh 2 decimal places
003EH	62	Forward active energy consumption	4	R	
0040H	64	Reversing active energy consumption	4	R	
0042H	66	Forward reactive energy consumption	4	R	Uint32 unit kVarh 2 decimal places
0044H	68	Reversing reactive energy consumption	4	R	
0046H	70	Total energy consumption on A phase	4	R	Uint32 unit kWh 2 decimal places
0048H	72	Forward active energy consumption on A phase	4	R	
004AH	74	Reversing active energy consumption on A phase	4	R	
004CH	76	Forward reactive energy consumption on A phase	4	R	Uint32 unit kVarh 2 decimal places
004EH	78	Reversing reactive energy consumption on A phase	4	R	
0050H	80	Total energy consumption on B phase	4	R	Uint32 unit kWh 2 decimal places

0052H	82	Forward active energy consumption on B phase	4	R	
0054H	84	Reversing active energy consumption on B phase	4	R	
0056H	86	Forward reactive energy consumption on B phase	4	R	Uint32 unit kVarh 2 decimal places
0058H	88	Reversing reactive energy consumption on B phase	4	R	
005AH	90	Total energy consumption on C phase	4	R	Uint32 unit kWh 2 decimal places
005CH	92	Forward active energy consumption on C phase	4	R	
005EH	94	Reversing active energy consumption on C phase	4	R	
0060H	96	Forward reactive energy consumption on C phase	4	R	Uint32 unit kVarh 2 decimal places
0062H	98	Reversing reactive energy consumption on C phase	4	R	
0064H	100	Maximum forward active demand in current month	4	R	Uint32 unit KW 3 decimal places
0066H~0067H	102-103	Occur time	4	R	Minute, hour, day, month
0068H	104	Maximum reversing active demand in current month	4	R	Uint32 unit kVar 3 decimal places

006AH~006BH	106-107	Occur time	4	R	Minute, hour, day, month
006CH	108	Maximum forward reactive demand in current month	4	R	Uint32 unit kVar 3 decimal places
006EH~006FH	110-111	Occur time	4	R	Minute, hour, day, month
0070H	112	Maximum reversing reactive demand in current month	4	R	Uint32 unit kVar 3 decimal places
0072H~0073H	114-115	Occur time	4	R	Minute, hour, day, month
0074H	116	THDUa	2	R	Total distortion rate of voltage and current on each phase Uint16 2 decimal places
0075H	117	THDUb	2	R	
0076H	118	THDUc	2	R	
0077H	119	THDIa	2	R	
0078H	120	THDIb	2	R	
0079H	121	THDIc	2	R	
007AH	122	THUa(Harmonic on 2nd-31st)	2×30	R	Harmonic voltage on 2nd-31st Uint16 2 decimal places
0098H	152	THUa(Harmonic on 2nd-31st)	2×30	R	
00B6H	182	THUb(Harmonic on 2nd-31st)	2×30	R	
00D4H	212	THUc(Harmonic on 2nd-31st)	2×30	R	Harmonic current on 2nd-31st Uint16 2 decimal places
00F2H	242	THIa(Harmonic on 2nd-31st)	2×30	R	
0110H	272	THIb(Harmonic on 2nd-31st)	2×30	R	
012EH	302	Fundamental voltage on A phase	2	R	Uint16 unit V 1 decimal places
012FH	303	Fundamental voltage on B phase	2	R	
0130H	304	Fundamental voltage on C phase	2	R	
0131H	305	Harmonic voltage on A phase	2	R	
0132H	306	Harmonic voltage on B phase	2	R	
0133H	307	Harmonic voltage	2	R	

		on C phase			
0134H	308	Fundamental current on A phase	2	R	Uint16 unit A 2 decimal places
0135H	309	Fundamental current on B phase	2	R	
0136H	310	Fundamental current on C phase	2	R	
0137H	311	Harmonic current on A phase	2	R	
0138H	312	Harmonic current on B phase	2	R	
0139H	313	Harmonic current on C phase	2	R	
013AH	314	Fundamental active power on A phase	4	R	Int32 unit kW 3 decimal places
013CH	316	Fundamental active power on B phase	4	R	
013EH	318	Fundamental active power on C phase	4	R	
0140H	320	Fundamental active power	4	R	
0142H	322	Fundamental reactive power on A phase	4	R	Int32 unit kVar 3 decimal places
0144H	324	Fundamental reactive power on B phase	4	R	
0146H	326	Fundamental reactive power on C phase	4	R	
0148H	328	Fundamental reactive power	4	R	
014AH	330	Harmonic active power on A phase	4	R	
014CH	332	Harmonic active power on B phase	4	R	Int32 unit kW 3 decimal places
014EH	334	Harmonic active power on C phase	4	R	
0150H	336	Harmonic active power	4	R	

0152H	338	Harmonic reactive power on A phase	4	R	Int32 unit kVar 3 decimal places
0154H	340	Harmonic reactive power on B phase	4	R	
0156H	342	Harmonic reactive power on C phase	4	R	
0158H	344	Harmonic reactive power	4	R	
015AH	346	Current forward active demand	4	R	Uint32 unit kW 3 decimal places
015CH	348	Current reversing active demand	4	R	
015EH	350	Current forward reactive demand	4	R	Uint32 unit kVar 3 decimal places
0160H	352	Current reversing reactive demand	4	R	
0162H	354	Voltage imbalance	2	R	Uint16 unit 0.01%
0163H	355	Current imbalance	2	R	
0164H	356	Temperature on A phase	2	R	Int16 unit 0.1°C
0165H	357	Temperature on B phase	2	R	
0166H	358	Temperature on C phase	2	R	
0167H	359	Time zone number/Time zone date: day	2	R/W	Time list
0168H	360	Time zone date: month/Time zone number	2	R/W	
0169H	361	Time zone date: day/ Time zone date: month	2	R/W	
016AH	362	Time zone number/Time zone date: day	2	R/W	
016BH	363	Time zone date: month/Time zone number	2	R/W	
016CH	364	Time zone date: day/ Time zone	2	R/W	

		date: month				
016DH ... 0181H	365-385	1-14 period of time Parameters setting information	2	R/W	1# time list	
0182H ... 0196H	386-406	1-14 period of time Parameters setting information	2	R/W	2# time list	
0197H	407	Current total spike active energy	4	R	Uint32 unit kWh 2 decimal places	
0199H	409	Current total peak active energy	4	R		
019BH	411	Current total flat active energy	4	R		
019DH	413	Current total valley active energy	4	R		
019FH	415	Current total spike forward active energy	4	R		
01A1H	417	Current total peak forward active energy	4	R		
01A3H	419	Current total flat forward active energy	4	R		
01A5H	421	Current total valley forward active energy	4	R		
01A7H	423	Current total spike reversing active energy	4	R		
01A9H	425	Current total peak reversing active energy	4	R		
01ABH	427	Current total flat reversing active energy	4	R		
01ADH	429	Current total valley reversing active energy	4	R		
01AFH	431	Current total spike forward reactive	4	R		Uint32 unit kVarh

		energy			2 decimal places
01B1H	433	Current total peak forward reactive energy	4	R	
01B3H	435	Current total flat forward reactive energy	4	R	
01B5H	437	Current total valley forward reactive energy	4	R	
01B7H	439	Current total spike reversing reactive energy	4	R	
01B9H	441	Current total peak reversing reactive energy	4	R	
01BBH	443	Current total flat reversing reactive energy	4	R	
01BDH	445	Current total valley reversing reactive energy	4	R	
01BFH	447	wireless signal strength	2	R	
01C0H	448	Freeze time	2	R/W	High byte:Hour, low byte:DAY
01C1H	449	Aftercurrent	2	R	Uint16 unit mA
01C2H	450	DO1	2	R/W	Uint16 Bit0 effective
01C3H	451	DO2	2	R/W	Uint16 Bit0 effective
01C4H	452	Demand cycle	2	R/W	1: 15min 2: 30min 3: 45min 4: 60min
01C5H-01CFH	453-463	reserved			
01D0H-01EBH	464-491	Related data of alarm 1, see section 6.3.1 for details			
01ECH	492	A phase voltage Angle	2	R	Uint16 2 decimal places

01EDH	493	B phase voltage Angle	2	R	
01EEH	494	C phase voltage Angle	2	R	
01EFH	495	reserved			
01FOH	496	Protocol selection bit	2	R/W	0: 安全用电 1: 电力运维
01F2H	498	Real-time perceived demand	4	R	Uint32 unit kVA 3 decimal places
01F4H	500	Combined reactive electric energy	4	R	Uint32 unit kVarh 3 decimal places
01F6H	502	Current first quadrant of reactive energy	4	R	
01F8H	504	Current second quadrant reactive energy	4	R	
01FAH	506	Current third quadrant of reactive energy	4	R	
01FCH	508	Current fourth quadrant reactive energy	4	R	
01FEH	510	A phase current Angle	2	R	Uint16 2 decimal places
01FFH	511	B phase current Angle	2	R	
0200H	512	C phase current Angle	2	R	
0201H-0215H	513-533	1-14 period of time Parameters setting information	2	R/W	3# time list
0216H-0249H	534-585	Related data of alarm 2 and alarm 3, see section 6.3.2 for details			
024AH-0267H	586-615	reserved			
0268H-0169H	616-617	Alarm status of alarm 2 and alarm 3, see section			

		6.3.2 for details			
--	--	-------------------	--	--	--

6.3 Alarm function related Settings

6.3.1 Alarm 1 related parameter register address table

Start Address (Hexadecimal)	Start Address (Decimal)	Variable	Length	R/W	Notes
01EBH	491	Alarm 1 status	2	R	Bit0: overvoltage alarm permission bits Bit1: undervoltage alarm permission bits Bit2: overcurrent alarm permission bits Bit3: undercurrent alarm permission bits Bit4: overpower alarm permission bits Bit5: underpower alarm permission bits Bit6:DO1alarm bit7:DO2alarm Bit8:Phase A loses current alarm Bit9:Phase B loses current alarm Bit10:Phase C loses current alarm Bit11:Phase A loses voltaget alarm Bit12:Phase B loses voltaget alarm Bit13:Phase C loses voltaget alarm Bit14:Phase sequence error alarm Bit15:Power is reported
01DOH	464	Alarm permission bits	2	R/W	Bit0: overvoltage alarm permission bits Bit1: undervoltage alarm permission bits Bit2: overcurrent alarm

					permission bits Bit3: undercurrent alarm permission bits Bit4: overpower alarm permission bits Bit5: underpower alarm permission bits Bit6:DO1alarm bits bit7:DO2alarm bits Bit8:Phase A loses current alarm bits Bit9:Phase B loses current alarm bits Bit10:Phase C loses current alarm bits Bit11:Phase A loses voltaget alarm bits Bit12:Phase B loses voltaget alarm bits Bit13:Phase C loses voltaget alarm bits Bit14:Phase sequence error alarm bits Bit15:Power is reported bits
01D1H	465	overvoltage alarm threshold	2	R/W	Uint16 unit 0.1V
01D2H	466	overvoltage alarm time-delay	2	R/W	Uint16 unit 0.01S
01D3H	467	undervoltage alarm threshold	2	R/W	Uint16 unit 0.1V
01D4H	468	undervoltage alarm time-delay	2	R/W	Uint16 unit 0.01S
01D5H	469	overcurrent alarm threshold	2	R/W	Uint16 unit 0.01A
01D6H	470	Overcurrent alarm time-delay	2	R/W	Uint16 unit 0.01S
01D7H	471	undercurrent alarm threshold	2	R/W	Uint16 unit 0.01A
01D8H	472	undercurrent alarm time-delay	2	R/W	Uint16 unit 0.01S
01D9H	473	overpower alarm threshold	2	R/W	Uint16 unit 0.001kw
01DAH	474	overpower alarm	2	R/W	Uint16

		time-delay			unit 0.01S
01DBH	475	underpower alarm threshold	2	R/W	Uint16 unit 0.001kw
01DCH	476	underpower alarm time-delay	2	R/W	Uint16 unit 0.01S
01DDH	477	DI1 Original state	2	R/W	0:Normal Open 1:Normal Close
01DEH	478	DI1 Setting	2	R/W	0:Not associated to DO 1:Associated to DO1 2:Associated to DO2
01DFH	479	DI2 Original state	2	R/W	0:Normal Open 1:Normal Close
01E0H	480	DI2 Setting	2	R/W	0:Not associated to DO 1:Associated to DO1 2:Associated to DO2
01E1H	481	DI3 Original state	2	R/W	0:Normal Open 1:Normal Close
01E2H	482	DI3 Setting	2	R/W	0:Not associated to DO 1:Associated to DO1 2:Associated to DO2
01E3H	483	DI4 Original state	2	R/W	0:Normal Open 1:Normal Close
01E4H	484	DI4 Setting	2	R/W	0:Not associated to DO 1:Associated to DO1 2:Associated to DO2
01E5H	485	DO1 Output mode	2	R/W	0:Electrical level 1:Purse
01E6H	486	DO1 Related content	2	R/W	0:DO 1: Total failure 2: Total failure +DI1+DI2 3:DI1 4:DI2 5:DI1+DI2
01E7H	487	DO1 Output pulse width	2	R/W	0:None 1:1S 2:2S 3:3S 4:4S 5:5S
01E8H	488	DO2 Output mode	2	R/W	0: Electrical level 1:Purse
01E9H	489	DO2 Related content	2	R/W	0:DO 1:Total failure 2: Total failure +DI1+DI2

					3:DI1 4:DI2 5:DI1+DI2
01EAH	490	DO2 Output pulse width	2	R/W	0:None 1:1S 2:2S 3:3S 4:4S 5:5S

6.3.2 Alarm 2, alarm 3 related parameter register address table

Start Address (Hexadecimal)	Start Address (Decimal)	Variable	Length	R/W	Notes
0216H	534	Alarm 2 allowed bit	2	R/W	Bit0:A phase power factor is too low alarm allowed bit Bit1:B phase power factor is too low alarm allowed bit Bit2:C phase power factor is too low alarm allowed bit Bit3:Total power factor is too low alarm allowed bit Bit4:Phase A overtemperature alarm allowed bit Bit5:Phase B overtemperature alarm allowed bit Bit6:Phase C overtemperature alarm allowed bit bit7:Phase N overtemperature alarm allowed bit Bit8:UA Total distortion is too high alarm allowed bit Bit9:UB Total distortion is too high alarm allowed bit Bit10:UC Total distortion is too high alarm allowed bit

					Bit11:IA Total distortion is too high alarm allowed bit Bit12:IB Total distortion is too high alarm allowed bit Bit13:IC Total distortion is too high alarm allowed bit Bit14:Voltage imbalance exceeds the high alarm allowed bit Bit15:Current imbalance exceeds the high alarm allowed bit
0268H	616	Alarm 2 Alarm status	2	R	Corresponding to alarm 2 permit bit
0217H	535	Alarm 3 allowed bit	2	R/W	Bit0:The current positive active power demand is too high alarm permission bit Bit1:The current reverse active power demand is too high alarm allow bit Bit2:The current positive reactive power demand is too high alarm allowed bit Bit3:The current reverse reactive power demand is too high alarm allowed bit Bit4:The current view is that excessive demand alarm is allowed Bit5-Bit15:reserved
0269H	617	Alarm 3 Alarm status	2	R	Corresponding to alarm 3 permit bit
0218H	536	The a-phase power factor excessive alarm threshold	2	R/W	Uint16 Unit 0.001
0219H	537	The a-phase power factor excessive alarm delay	2	R/W	Uint16 Unit 0.01S
021AH	538	The b-phase power factor excessive alarm threshold	2	R/W	Uint16 Unit 0.001
021BH	539	The b-phase power factor excessive alarm delay	2	R/W	Uint16 Unit 0.01S
021CH	540	The c-phase power factor excessive alarm threshold	2	R/W	Uint16 Unit 0.001

021DH	541	The c-phase power factor excessive alarm delay	2	R/W	Uint16 Unit 0.01S
021EH	542	total power factor excessive alarm threshold	2	R/W	Uint16 Unit 0.001
021FH	543	total power factor excessive alarm delay	2	R/W	Uint16 Unit 0.01S
0220H	544	A phase overtemperature alarm threshold	2	R/W	Uint16 Unit 0.1℃
0221H	545	A phase overtemperature alarm delay	2	R/W	Uint16 Unit 0.01S
0222H	546	B phase overtemperature alarm threshold	2	R/W	Uint16 Unit 0.1℃
0223H	547	B phase overtemperature alarm delay	2	R/W	Uint16 Unit 0.01S
0224H	548	C phase overtemperature alarm threshold	2	R/W	Uint16 Unit 0.1℃
0225H	549	C phase overtemperature alarm delay	2	R/W	Uint16 Unit 0.01S
0226H	550	N phase overtemperature alarm threshold	2	R/W	Uint16 Unit 0.1℃
0227H	551	N phase overtemperature alarm delay	2	R/W	Uint16 Unit 0.01S
0228H	552	UA total distortion excessive alarm threshold	2	R/W	Uint16 2 decimal places
0229H	553	UA total distortion excessive alarm delay	2	R/W	Uint16 Unit 0.01S
022AH	554	UB total distortion excessive alarm threshold	2	R/W	Uint16 2 decimal places
022BH	555	UB total distortion excessive alarm delay	2	R/W	Uint16 Unit 0.01S
022CH	556	UC total distortion excessive alarm threshold	2	R/W	Uint16 2 decimal places
022DH	557	UC total distortion excessive alarm delay	2	R/W	Uint16 Unit 0.01S
022EH	558	IA total distortion excessive alarm threshold	2	R/W	Uint16 2 decimal places
022FH	559	IA total distortion excessive alarm delay	2	R/W	Uint16 Unit 0.01S
0230H	560	IB total distortion excessive alarm threshold	2	R/W	Uint16 2 decimal places
0231H	561	IB total distortion excessive alarm delay	2	R/W	Uint16 Unit 0.01S
0232H	562	IC total distortion excessive alarm	2	R/W	Uint16

		threshold			2 decimal places
0233H	563	IC total distortion excessive alarm delay	2	R/W	Unit16 Unit 0.01S
0234H	564	Voltage imbalance overpasses high alarm threshold	2	R/W	Unit16 Unit 0.01%
0235H	565	Voltage imbalance overpasses high alarm delay	2	R/W	Unit16 Unit 0.01S
0236H	566	Current imbalance exceeds the upper alarm threshold	2	R/W	Unit16 Unit 0.01%
0237H	567	Current imbalance exceeds high alarm delay	2	R/W	Unit16 Unit 0.01S
0238H	568	The current positive active power demand exceeds the alarm threshold	4	R/W	Unit32 unit kW 3 decimal places
023AH	570	The current reverse active power demand is too high alarm delay	2	R/W	Unit16 Unit 0.01S
023BH	571	The current positive active power demand exceeds the alarm threshold	4	R/W	Unit32 Unit kW 3 decimal places
023DH	573	The current reverse active power demand is too high alarm delay	2	R/W	Unit16 Unit 0.01S
023EH	574	The current positive reactive power demand exceeds the alarm threshold	4	R/W	Unit32 Unit Kvar 3 decimal places
0240H	576	The current positive reactive power demand is too high alarm delay	2	R/W	Unit16 Unit 0.01S
0241H	577	The current reverse reactive power demand exceeds the alarm threshold	4	R/W	Unit32 Unit Kvar 3 decimal places
0243H	579	The current reverse reactive power demand is too high alarm delay	2	R/W	Unit16 Unit 0.01S
0244H	580	Excessive residual current alarm threshold	4	R/W	Unit32 Unit A 3 decimal places
0246H	582	Excessive residual current alarm delay	2	R/W	Unit16 Unit 0.01S
0247H	583	Current perceived excessive demand alarm threshold	4	R/W	Unit32 Unit KVA 3 decimal places
0249H	585	Excessive demand is currently seen as alarm delay	2	R/W	Unit16 Unit 0.01S

6.4 Primary Value Address Table

Table1:(Electrical parameter primary value)

Start Address (Hexadecimal)	Start Address (Decimal)	Variable	Length (byte)	R/W	Notes
8000	32768	Voltage of Aphase	4	R	float32 unit V
8002	32770	Voltage of B phase	4	R	
8004	32772	Voltage of C phase	4	R	
8006	32774	Voltage between A-B	4	R	
8008	32776	Voltage between B-C	4	R	
800A	32778	Voltage between C-A	4	R	
800C	32780	Current of Aphase	4	R	float32 unit A
800E	32782	Current of B phase	4	R	
8010	32784	Current of C phase	4	R	
8012	32786	Vector sum of 3-phase current	4	R	
8014	32788	Active power of A phase	4	R	float32 unit kW
8016	32790	Active power of B phase	4	R	
8018	32792	Active power of C phase	4	R	
801A	32794	Total active power	4	R	
801C	32796	Reactive power of A phase	4	R	float32 unit kVar
801E	32798	Reactive power of B phase	4	R	
8020	32800	Reactive power of C phase	4	R	
8022	32802	Total reactive power	4	R	
8024	32804	Apparent power of A phase	4	R	float32 unit kVA

8026	32806	Apparent power of B phase	4	R	
8028	32808	Apparent power of C phase	4	R	
802A	32810	Total apparent power	4	R	
802C	32812	Power factor of A phase	4	R	float32
802E	32814	Power factor of B phase	4	R	
8030	32816	Power factor of C phase	4	R	
8032	32818	Total power factor	4	R	
8034	32820	Frequency of power	4	R	float32 unit HZ
8036	32822	The average phase voltage	4	R	float32 unit v
8038	32824	Line voltage average	4	R	
803A	32826	Current average	4	R	float32 unit A
803C	32828	Voltage imbalance	4	R	float32 unit 0.1%
803E	32830	Current imbalance	4	R	
8040	32832	residual voltage	4	R	float32 unit v
8042	32834	residual current	4	R	float32 unit A
8044	32836	A Power Angle	4	R	float32 unit 0.1°
8046	32838	B Power Angle	4	R	
8048	32840	C Power Angle	4	R	
804A	32842	Phase A voltage angle	4	R	
804C	32844	Phase B voltage angle	4	R	
804E	32846	Phase C voltage angle	4	R	

8050	32848	Phase A current angle	4	R	
8052	32850	Phase B current angle	4	R	
8054	32852	Phase C current angle	4	R	
8056	32854	Temp N	4	R	float32 unit 0.1°C
8058	32856	Temp1	4	R	
805A	32858	Temp2	4	R	
805C	32860	Temp3	4	R	
805E	32862	Temp4	4	R	
8060	32864	leakage current	4	R	float32 unit A

Table2: (Electric Energy primary value)

Start Address (Hexadecimal)	Start Address (Decimal)	Variable	Length (byte)	R/W	Notes
887E	34942	Total active energy	4	R	Float 32 unit kWh
8880	34944	Forward active energy consumption	4	R	
8882	34946	Reversing active energy consumption	4	R	
8884	34948	reserved	4	R	Float 32 unit kVar
8886	34950	Forward reactive energy consumption	4	R	
8888	34952	Reversing reactive energy consumption	4	R	
888A	34954	reserved	4	R	Float 32 unit kVAh
888C	34956	Current total spike active energy	4	R	Float 32 unit kWh
888E	34958	Current total peak active energy	4	R	
8890	34960	Current total flat active energy	4	R	
8892	34962	Current total valley active energy	4	R	
8894	34964	Current total spike forward active energy	4	R	
8896	34966	Current total peak forward active energy	4	R	
8898	34968	Current total flat forward active energy	4	R	
889A	34970	Current total valley forward active energy	4	R	
889C	34972	Current total spike reversing active	4	R	

		energy				
889E	34974	Current total peak reversing active energy	4	R		
88A0	34976	Current total flat reversing active energy	4	R		
88A2	34978	Current total valley reversing active energy	4	R		
88A4	34980	Current total spike forward reactive energy	4	R	Float 32 unit kVar	
88A6	34982	Current total peak forward reactive energy	4	R		
88A8	34984	Current total flat forward reactive energy	4	R		
88AA	34986	Current total valley forward reactive energy	4	R		
88AC	34988	Current total spike reversing reactive energy	4	R		
88AE	34990	Current total peak reversing reactive energy	4	R		
88B0	34992	Current total flat reversing reactive energy	4	R		
88B2	34994	Current total valley reversing reactive energy	4	R		
88B4	34996	Total active energy of A phase	4	R		Float 32 unit kWh

88B6	34998	Forward active energy consumption of A phase	4	R	
88B8	35000	Reversing active energy consumption of A phase	4	R	
88BA	35002	reserved	4	R	Float 32 unit kVar
88BC	35004	Forward reactive energy consumption of A phase	4	R	Float 32 unit kVar
88BE	35006	Reversing reactive energy consumption of A phase	4	R	
88C0	35008	reserved	4	R	Float 32 unit kWh
88C2	35010	reserved	4	R	
88C4	35012	reserved	4	R	
88C6	35014	reserved	4	R	
88C8	35016	Total active energy of B phase	4	R	Float 32 unit kWh
88CA	35018	Forward active energy consumption of B phase	4	R	
88CC	35020	Reversing active energy consumption of B phase	4	R	
88CE	35022	reserved	4	R	Float 32 unit kVar
88D0	35024	Forward reactive energy consumption of B phase	4	R	Float 32 unit kVar
88D2	35026	Reversing reactive energy consumption	4	R	

		of B phase			
88D4	35028	reserved	4	R	Float 32 unit kWh
88D6	35030	reserved	4	R	
88D8	35032	reserved	4	R	
88DA	35034	reserved	4	R	
88DC	35036	Total active energy of C phase	4	R	Float 32 unit kWh
88DE	35038	Forward active energy consumption on C phase	4	R	
88E0	35040	Reversing active energy consumption on C phase	4	R	
88E2	35042	reserved	4	R	Float 32 unit kVar
88E4	35044	Forward reactive energy consumption on C phase	4	R	Float 32 unit kVar
88E6	35046	Reversing reactive energy consumption on C phase	4	R	
88E8	35048	reserved	4	R	Float 32 unit kWh
88EA	35050	reserved	4	R	
88EC	35052	reserved	4	R	
88EE	35054	reserved	4	R	
88F0	35056	Quadrant 1: total reactive electric energy	4	R	Float 32 unit kVar
88F2	35058	Quadrant 2: total reactive electric energy	4	R	
88F4	35060	Quadrant 3: total	4	R	

		reactive electric energy			
88F6	35062	Quadrant 4: total reactive electric energy	4	R	
88F8	35064	reserved	4	R	Float 32 unit kWh
88FA	35066	reserved	4	R	Float 32 unit kVar

Table (Secondary value):

Start Address (Hexadecimal)	Start Address (Decimal)	Variable	Length (byte)	R/W	Notes
8800	34816	Total active energy	4	R	Uint 16 unit kWh
8802	34818	Forward active energy consumption	4	R	
8804	34820	Reversing active energy consumption	4	R	
8806	34822	reserved	4	R	Uint 16 unit kVar
8808	34824	Forward reactive energy consumption	4	R	
880A	34826	Reversing reactive energy consumption	4	R	
880C	34828	reserved	4	R	Uint 16 unit kVAh
880E	34830	Current total spike active energy	4	R	Uint 16 unit kWh
8810	34832	Current total peak active energy	4	R	
8812	34834	Current total flat active energy	4	R	
8814	34836	Current total valley active energy	4	R	
8816	34838	Current total spike forward active energy	4	R	
8818	34840	Current total peak forward active energy	4	R	
881A	34842	Current total flat forward active energy	4	R	
881C	34844	Current total valley forward active	4	R	

		energy			
881E	34846	Current total spike reversing active energy	4	R	
8820	34848	Current total peak reversing active energy	4	R	
8822	34850	Current total flat reversing active energy	4	R	
8824	34852	Current total valley reversing active energy	4	R	
8826	34854	Current total spike forward reactive energy	4	R	Uint 16 unit kVar
8828	34856	Current total peak forward reactive energy	4	R	
882A	34858	Current total flat forward reactive energy	4	R	
882C	34860	Current total valley forward reactive energy	4	R	
882E	34862	Current total spike reversing reactive energy	4	R	
8830	34864	Current total peak reversing reactive energy	4	R	
8832	34866	Current total flat reversing reactive energy	4	R	
8834	34868	Current total valley reversing reactive energy	4	R	

8836	34870	Total active energy of A phase	4	R	Unit 16 unit kWh
8838	34872	Forward active energy consumption of A phase	4	R	
883A	34874	Reversing active energy consumption of A phase	4	R	
883C	34876	reserved	4	R	Unit 16 unit kVar
883E	34878	Forward reactive energy consumption of A phase	4	R	Unit 16 unit kVar
8840	34880	Reversing reactive energy consumption of A phase	4	R	
8842	34882	reserved	4	R	Unit 16 unit kWh
8844	34884	reserved	4	R	
8846	34886	reserved	4	R	
8848	34888	reserved	4	R	
884A	34890	Total active energy of B phase	4	R	Unit 16 unit kWh
884C	34892	Forward active energy consumption of B phase	4	R	

884E	34894	Reversing active energy consumption of B phase	4	R	
8850	34896	reserved	4	R	Unit 16 unit kVar
8852	34898	Forward reactive energy consumption of B phase	4	R	Unit 16 unit kVar
8854	34900	Reversing reactive energy consumption of B phase	4	R	
8856	34902	reserved	4	R	Unit 16 unit kWh
8858	34904	reserved	4	R	
885A	34906	reserved	4	R	
885C	34908	reserved	4	R	
885E	34910	Total active energy of C phase	4	R	Unit 16 unit kWh
8860	34912	Forward active energy consumption on C phase	4	R	
8862	34914	Reversing active energy consumption on C phase	4	R	
8864	34916	reserved	4	R	Unit 16 unit kVar
8866	34918	Forward reactive energy consumption on C phase	4	R	Unit 16 unit kVar
8868	34920	Reversing reactive energy consumption on C phase	4	R	

886A	34922	reserved	4	R	Uint 16 unit kWh
886C	34924	reserved	4	R	
886E	34926	reserved	4	R	
8870	34928	reserved	4	R	
8872	34930	Quadrant 1: total reactive electric energy	4	R	Uint 16 unit kVar
8874	34932	Quadrant 2: total reactive electric energy	4	R	
8876	34934	Quadrant 3: total reactive electric energy	4	R	
8878	34936	Quadrant 4: total reactive electric energy	4	R	
887A	34938	reserved	4	R	Uint 16 unit kWh
887C	34940	reserved	4	R	Uint 16 unit kVar

6.5 Historical Data Memory

Start address (high byte)	Data type
48-53H	Last 1 month-last 12 months

Start address (low byte)	Data type
00H	Record date and time
03H	History total active energy
05H	History total forward active energy
07H	History total reversing active energy
09H	History total forward reactive energy
0BH	History total reversing reactive energy
0DH	Total active energy on A phase
0FH	Total forward active energy on A phase
11H	Total reversing active energy on A phase
13H	Total forward reactive energy on A phase
15H	Total reversing reactive energy on A phase
17H	Total active energy on B phase
19H	Total forward active energy on B phase
1BH	Total reversing active energy on B phase
1DH	Total forward reactive energy on B phase
1FH	Total reversing reactive energy on B phase
21H	Total active energy on C phase
23H	Total forward active energy on C phase
25H	Total reversing active energy on C phase
27H	Total forward reactive energy on C phase
29H	Total reversing reactive energy on C phase
2BH	Current spike electric energy
2DH	Current peak electric energy
2FH	Current flat electric energy
31H	Current valley electric energy
33H	Current forward active spike electric energy
35H	Current forward active peak electric energy
37H	Current forward active flat electric energy
39H	Current forward active valley electric energy
3BH	Current reversing active spike electric energy
3DH	Current reversing Active peak electric energy
3FH	Current reversing active flat electric energy
41H	Current reversing Active valley electric energy
43H	Current forward reactive spike electric energy

45H	Current forward reactive spike electric energy
47H	Current forward reactive flat electric energy
49H	Current forward reactive valley electric energy
4BH	Current reversing reactive spike electric energy
4DH	Current reversing reactive peak electric energy
4FH	Current reversing reactive flat electric energy
51H	Current reversing reactive valley electric energy

6.6 Record of extreme value and occurrence time

1) Maximum records:

Starting address of interval (high byte)	Type of historical data
04	Extremum of the month and Occurrence time
05	Extremum of last 1 month and Occurrence time
06	Extremum of last 2 month and Occurrence time
07	Extremum of last 3 month and Occurrence time

Offset address of interval (low byte)	Data type
00	Voltage of A phase maximum value and occurrence time
03	Voltage of B phase maximum value and occurrence time
06	Voltage of C phase maximum value and occurrence time
09	Voltage between A-B maximum value and occurrence time
0C	Voltage between A-B maximum value and occurrence time
0F	Voltage between A-B maximum value and occurrence time
12	Electricity of A phase maximum value and occurrence time
15	Electricity of B phase maximum value and occurrence time
18	Electricity of C phase maximum value and occurrence time
1B	Three phase current vector sum maximum value and occurrence time
1E	Active power of A phase maximum value and occurrence time
22	Active power of B phase maximum value and occurrence time
26	Active power of C phase maximum value and occurrence time

2A	Total active power maximum value and occurrence time
2E	Reactive power of A phase maximum value and occurrence time
32	Reactive power of B phase maximum value and occurrence time
36	Reactive power of C phase maximum value and occurrence time
3A	Total reactive power maximum value and occurrence time
3E	Apparent power of A phase maximum value and occurrence time
42	Apparent power of B phase maximum value and occurrence time
46	Apparent power of C phase maximum value and occurrence time
4A	Total apparent power maximum value and occurrence time

2) **Minimum record:**

Starting address of interval (high byte)	Type of historical data
04	Extremum of the month and Occurrence time
05	Extremum of last 1 month and Occurrence time
06	Extremum of last 2 month and Occurrence time
07	Extremum of last 3 month and Occurrence time

Offset address of interval (low byte)	Data type
4E	Voltage of A phase Minimum Value and occurrence time
51	Voltage of B phase Minimum Value and occurrence time
54	Voltage of C phase Minimum Value and occurrence time
57	Voltage between A-B Minimum Value and occurrence time
5A	Voltage between B-C Minimum value and occurrence time
5D	Voltage between C-A Minimum value and occurrence time
60	Electricity of A phase Minimum value and occurrence time
63	Electricity of B phase Minimum value and occurrence time
66	Electricity of C phase Minimum value

	and occurrence time
69	Three phase current vector sum Minimum value and occurrence time
6C	Active power of A phase Minimum value and occurrence time
70	Active power of B phase Minimum value and occurrence time
74	Active power of C phase Minimum value and occurrence time
78	Total active power Minimum value and occurrence time
7C	Reactive power of A phase Minimum value and occurrence time
80	Reactive power of B phase Minimum value and occurrence time
84	Reactive power of C phase Minimum value and occurrence time
88	Total reactive power Minimum value and occurrence time
8C	Apparent power of A phase Minimum value and occurrence time
90	Apparent power of B phase Minimum value and occurrence time
94	Apparent power of C phase Minimum value and occurrence time
98	Total apparent power Minimum value and occurrence time

Note: The record of every extreme value and occurrence time is 6 bits, and the data configuration can be referred as below:

ADDRH ADDRL	Event names	Data type	Note
0400H	Maximum voltage of A phase and occurrence time	The data of Maximum voltage of A phase	data and decimal place refer to address table 6.2
0401H		Occurrence time of minutes and hours	high byte : minutes
0402H		Occurrence time of Days and months	high byte : Days

7 Common troubleshooting

7.1 RS485 networking communication failure

Suggestion: Please first confirm whether the RS485 wiring is loose, AB connection reverse and other problems, and then check the table through the button to see if the general selection parameters, such as address, baud rate, check digit, etc., are set correctly.

7.2 Wireless communication failure of instrumentation

Suggestion: Please connect RS485 interface on the meter and USB convert to 485 serial port to read the parameters, and confirm whether the parameters are the same as the upper terminal wireless configuration (channel and spread spectrum factor). If different, please modify the meter's wireless parameters and retest the master terminal after the same, and if the same, it may be the meter and master terminal are in a relative long distance. It is too far to communicate or the scene is seriously disturbed. We can try to use the external antenna at the same time, or consider the newly added wireless master terminals, and then test it.

Headquarters: Acrel Co., LTD.

Address: No.253 Yulv Road Jiading District, Shanghai, China

Postcode: 201801

Manufacturer: Jiangsu Acrel Electrical Manufacturing Co., LTD.

Address: No.5 Dongmeng Road,Dongmeng industrial Park, Nanzha Street, Jianguyin City, Jiangsu Province, China

Mobile/WhatsApp/WeChat: 0086 -188 6162 8731

Web-site: <https://www.acrel-electric.uk/>

Postcode: 214405

E-mail: elsie.ren@email.acrel.cn