

241



ADL10-E

Installation and operation instruction V2.2

ACREL Co.,Ltd

Declare

The copyright is the property of Acrel. Any information in any paragraph or section cannot be extracted, copied or otherwise reproduced or propagated. Otherwise offenders shall take all consequences.

All rights are reserved.

Acrel reserves the right to modify the product specifications herein without notification. Please consult the local agent about the latest specifications before placing a purchase order.

Content

1 Overview.....	1
2 Functions.....	1
3 Technical parameter.....	1
4 Overall dimensions.....	2
5 Wiring and installing.....	2
6 Display instructions.....	2
7 Communication instructions.....	3

1 Overview

ADL10-E single phase electric energy meter is a new generation energy meter designed by Acrel Co.,Ltd with many years' experience in designing electricity meters. Measurement, statistic, communication and LCD display functions are installed in the power meter. This power meter has advantages of high stability, low power consumption and data saving after blackout etc. All meters meet the related technical requirements of electronic power meter in the IEC62053-21、IEC62053-22 standards.

2 Functions

Function	Function description	Function provide
Measurement of kWh	Single-phase active kWh (positive and negative)	■
Measurement of electrical parameters	Voltage, Current, Active power, Reactive power, Apparent power, Power factor and Frequency	■
LCD Display	8 bits section LCD display	■
Communication	Communication interface: RS485, Communication protocol: MODBUS-RTU	□C

(■: means standard; □: means optional)

3 Technical parameter

3.1 Electric performance

Input voltage	Reference voltage	AC220V
	Reference frequency	50Hz
	Power consumption	<10VA
Input current	Basic current	10A
	Maximum current	60A
	Starting current	0.004I _b
	Consumption	<4VA (Maximum current)
Measurement performance	Accuracy of measuring	1 Class
	Range of measuring	000000.00~999999.99kWh
Communication	Interface	RS485(A+, B-)
	Connection mode	Shielded twisted pair conductors
	Protocol	MODBUS-RTU

3.2 Mechanical performance

Outline (Length × Width × Height)	18mm×96 mm×70mm
-----------------------------------	-----------------

3.3 Work environment

Range of temperature	Working temperature	-25°C~55°C
----------------------	---------------------	------------

	Storing temperature	-40°C~70°C
Relative humidity	≤95%(No condensation)	
Altitude	<2000m	

4 Overall dimensions

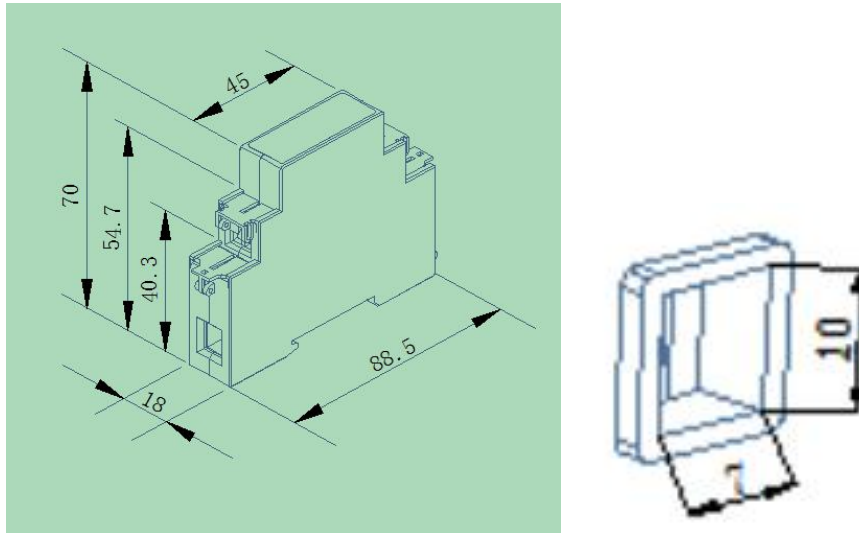

Note: The torque should not be greater than 4.0N·m

5 Wiring and installing

5.1 Wiring diagram

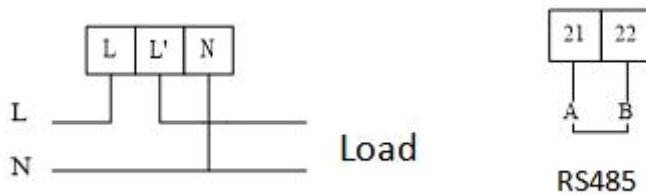

5.2 Installing notices

ADL10 single phase electric meter used the direct connecting method. Please pay attention to the direction of input and output while wiring and screw tightly (torque less than 12Nm) prevent the meter from the abnormal work.

6 Display instructions

The meter shows total energy first while turning on and then shows voltage, current and power, etc. in turn. The example shows as following:



Current total energy 12.34kWh

Current voltage 220.0V



Current current 10.00A

Current power 2.20kW



Power factor 1.00

Current even test, baud rate 9600



Current address 001

Current version V1.00

7 Communication instructions

7.1 Communication protocol

The meters adapt Modbus . Please refer to the relevant standards for more information.

7.2 MODBUS Communication address table

Address	Variable	Length	R/W	Notes
0000H	Current total energy	4	R	unit: 0.01kWh
0001H				
0002H	Reserved			
...				
000AH				
000BH	Voltage	2	R	unit: 0.1V
000CH	Current	2	R	unit: 0.01A
000DH	Active power	2	R	unit: 0.001kw
000EH	Reactive power	2	R	unit: 0.001kvar
000FH	Apparent power	2	R	unit: 0.001kVA
0010H	Power factor	2	R	unit: 0.001
0011H	Frequency	2	R	unit: 0.01Hz
0012H	Reserved			
...				
0014H				
0015H (high bit)	Address	1	R/W	1~247
0015H (low	Communication baud rate	1	R/W	00: 9600 01: 4800

bit)				02: 2400 03: 1200
0016H ... 0047H	Reserved			
0048H	Method of testing	2	R/W	02: even 00: none
0049H ... 004BH	Reserved			
004CH	Forward reactive energy	4	R	unit: 0.01kWh
004DH				
004EH	Reversing reactive energy	4	R	unit: 0.01kWh
004FH				
0050H ... 0067H	Reserved			
0068H	Forward active energy	4	R	Unit: 0.01kWh
0069H				
006AH ... 0071H	Reserved			
0072H	Reversing active energy	4	R	Unit: 0.01kWh
0073H				

Headquarters: Acrel Co., LTD.

Address: No.253 Yulv Road Jiading District, Shanghai, China

Postcode: 201801

Manufacturer: Jiangsu Acrel Electrical Manufacturing Co., LTD.

Address: No.5 Dongmeng Road,Dongmeng industrial Park, Nanzha Street,Jiangyin City,Jiangsu Province,China

MP/WhatsApp/WeChat: 0086 - 188 6162 8731

Web-site: <https://www.acrel-electric.uk/>

Postcode: 214405

E-mail: elsie.ren@email.acrel.cn